

IRONEDGE.

Pec Fly / Rear Delt

Setup Instructions

 CAUTION: Read all precautions and instructions before using this equipment. Save this manual for future reference.



Table Of Contents

Assembly Instructions.....	2-20
Part List.....	21

To Apply Thread Locker

The Fasteners marked by the sign  in the following assembling steps need to be bonded to prevent loosening, or the fasteners are a type of thread locking screws.

How to use

1. Degrease and clean surfaces prior to apply adhesive.
2. Insert bolt and apply adhesive to the exposed thread. Assemble nut and tighten to the correct torque (FIG 1).
3. Apply several drops of adhesive down the sides of the blind hole filling the lower third. Apply several drops to the bolt, Assemble and tighten (FIG 2).



Blue Thread Locker
Medium strength

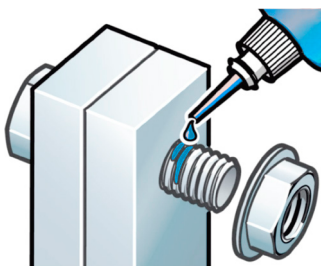

FIG 1

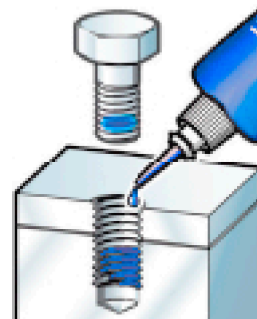

FIG 2

STEP 1

Parts

Part No: 1
Name: Main Frame
Q'TY:1



Part No: 2
Name: Plate Brace
Q'TY:1



Fixings

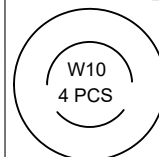

SC10 - 5 4 PCS

Tools



8 mm

Assemble the Main Frame (#1) and the Plate Brace(#2).

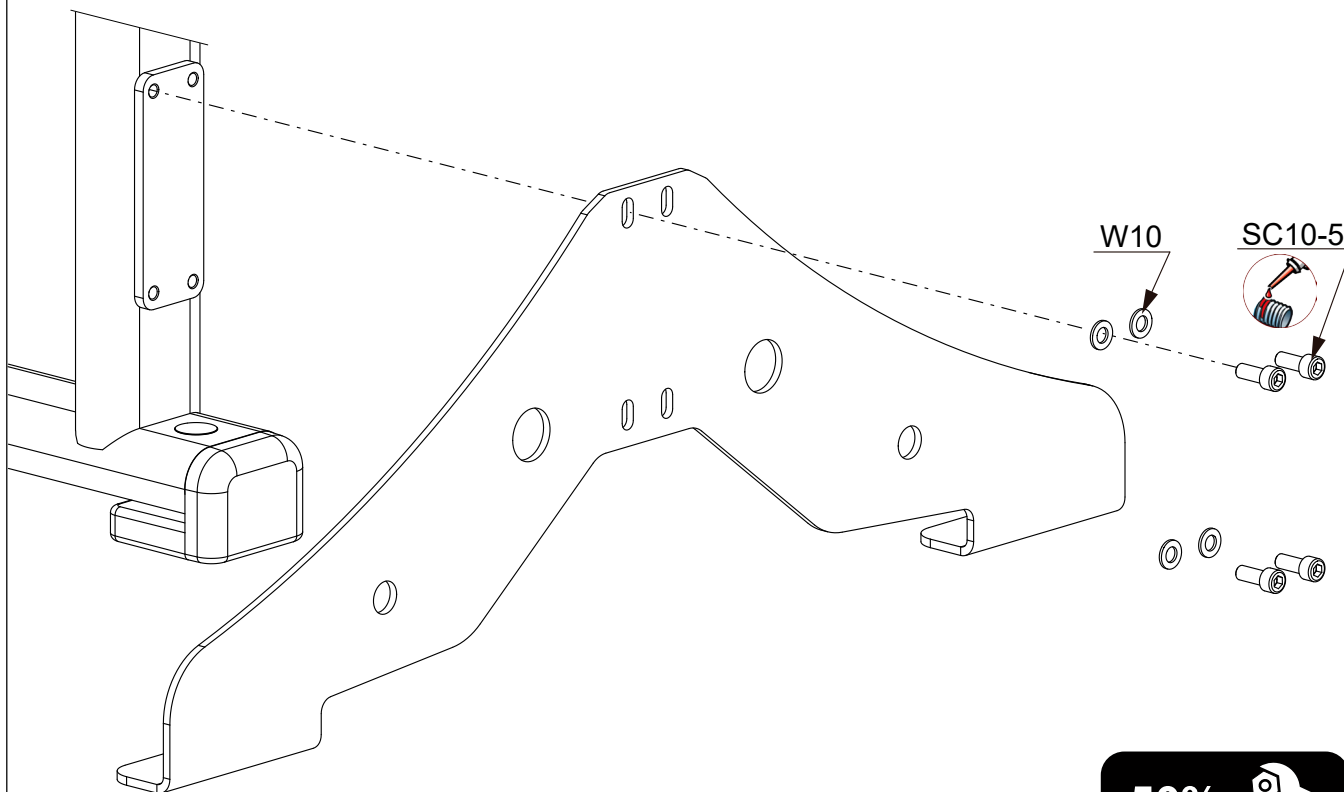
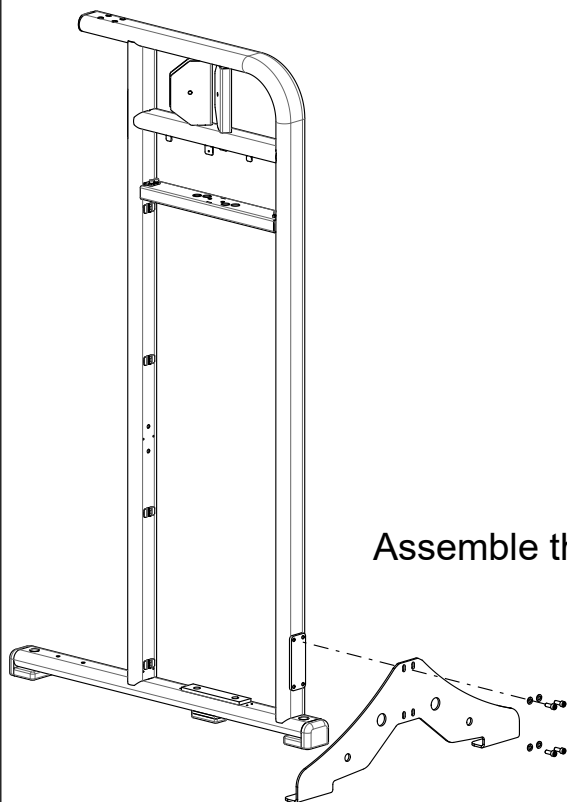

50%



STEP 2

Tools



Parts

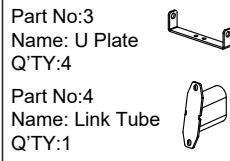

Fixings

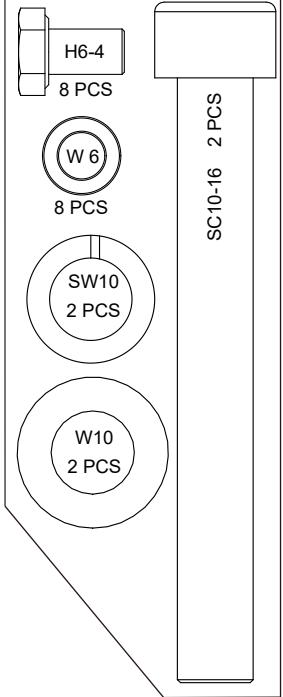

Install The U Plate(#3) and the Link Tube(#4).

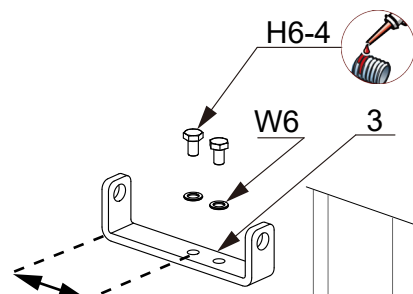
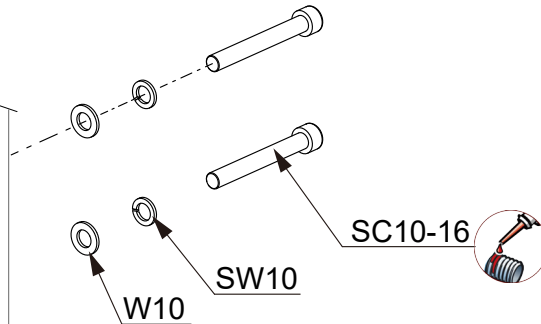
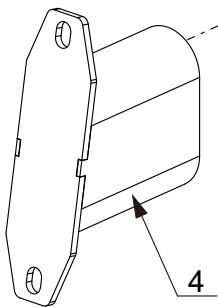
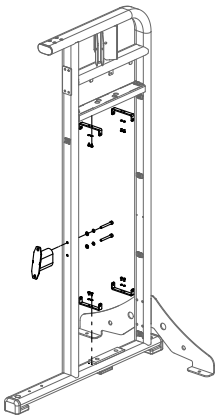

The longer side is close to #37 Back Shield.

50%



STEP 3

Install the Holding Plate(#7)

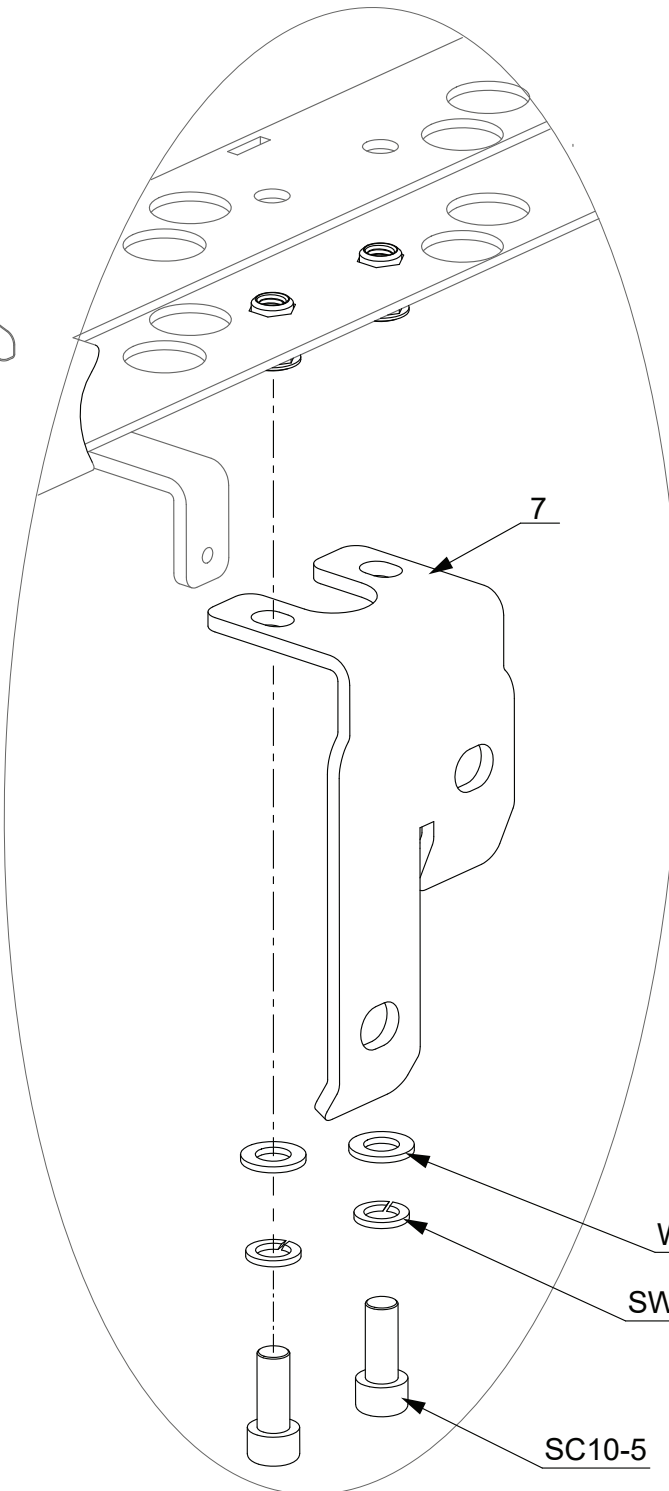
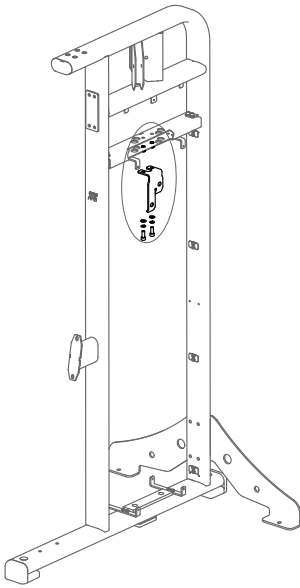

Fixings

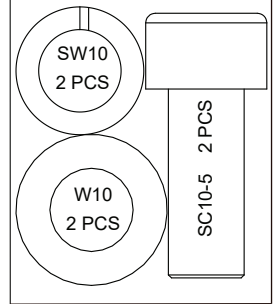

Parts

Part No:7
Name: Holding Plate
Q'TY:1

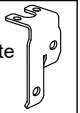

Tools



50%













Install the Weight Stack

STEP 4

Fixings

S8-7 2PCS

Parts

Part No: 5	
Name: Guide Rod	
Q'TY: 2	
Part No: 6	
Name: Rubber Buffer	
Q'TY: 2	
Part No: 8	
Name: Weight Label	
Q'TY: 1	
Part No: 9	
Name: Weight Plate 7.5 Kg	
Q'TY: 13	
Part No: 10	
Name: Weight Pin	
Q'TY: 1	
Part No: 11	
Name: Top Weight Plate	
Q'TY: 1	
Part No: 12	
Name: Pulley Holder	
Q'TY: 1	
Part No: 13	
Name: External Retaining Ring	
Q'TY: 2	
Part No: 14	
Name: Rod Retainer	
Q'TY: 2	
Part No: 39	
Name: Micro Weight Adjuster	
Q'TY: 2	

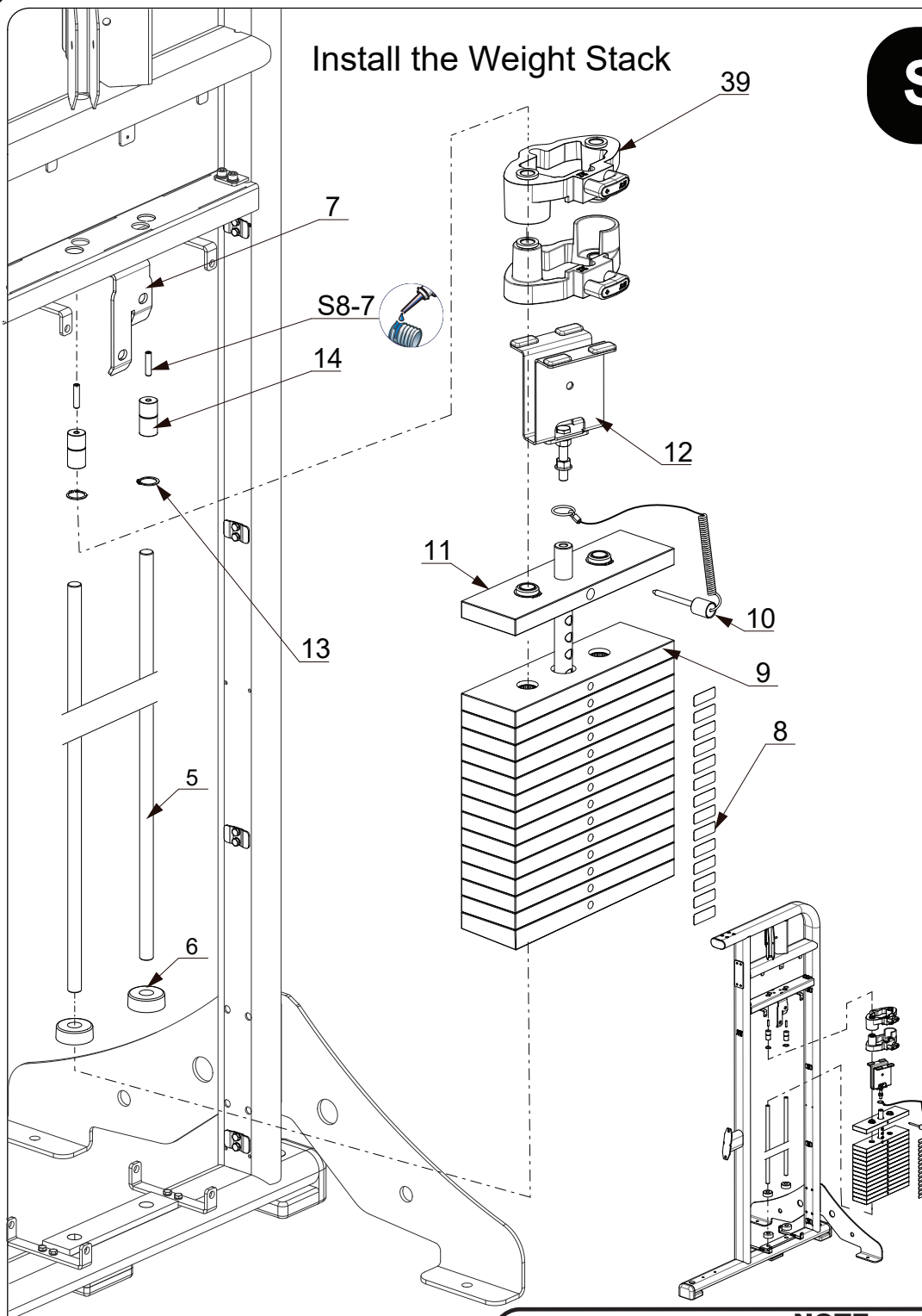

NOTE:

•In Step 4, if the Micro Weight Adjuster(39) is not smoothly sliding, please loosen the screws of the Holder(7) and adjust it by making sure the pin behind the number +2.5 is successfully inserted into the holes of Micro Weight Adjuster(39), then tighten the screw accordingly.

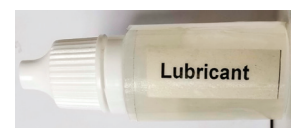

Note 1: please clean the weight plates Before sticking the weight labels , and avoid touching the adhesive of the sticker.

Note 2: If the movement of the weight stack is not smooth during exercising, please lubricate the guide rods.

50%



STEP 5

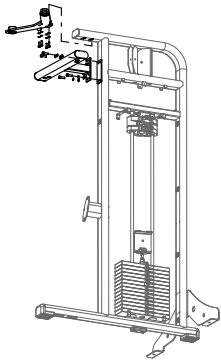

Install the Arm Support Tube(#15) and the Arm Support Plate(#16) on the Main Frame(#1).

Parts	
Part No:15	
Name: Arm Support Tube	
QTY:1	
Part No:16	
Name: Arm Support Plate	
QTY:1	

Fixings	

Tools	
	6 \ 8 mm

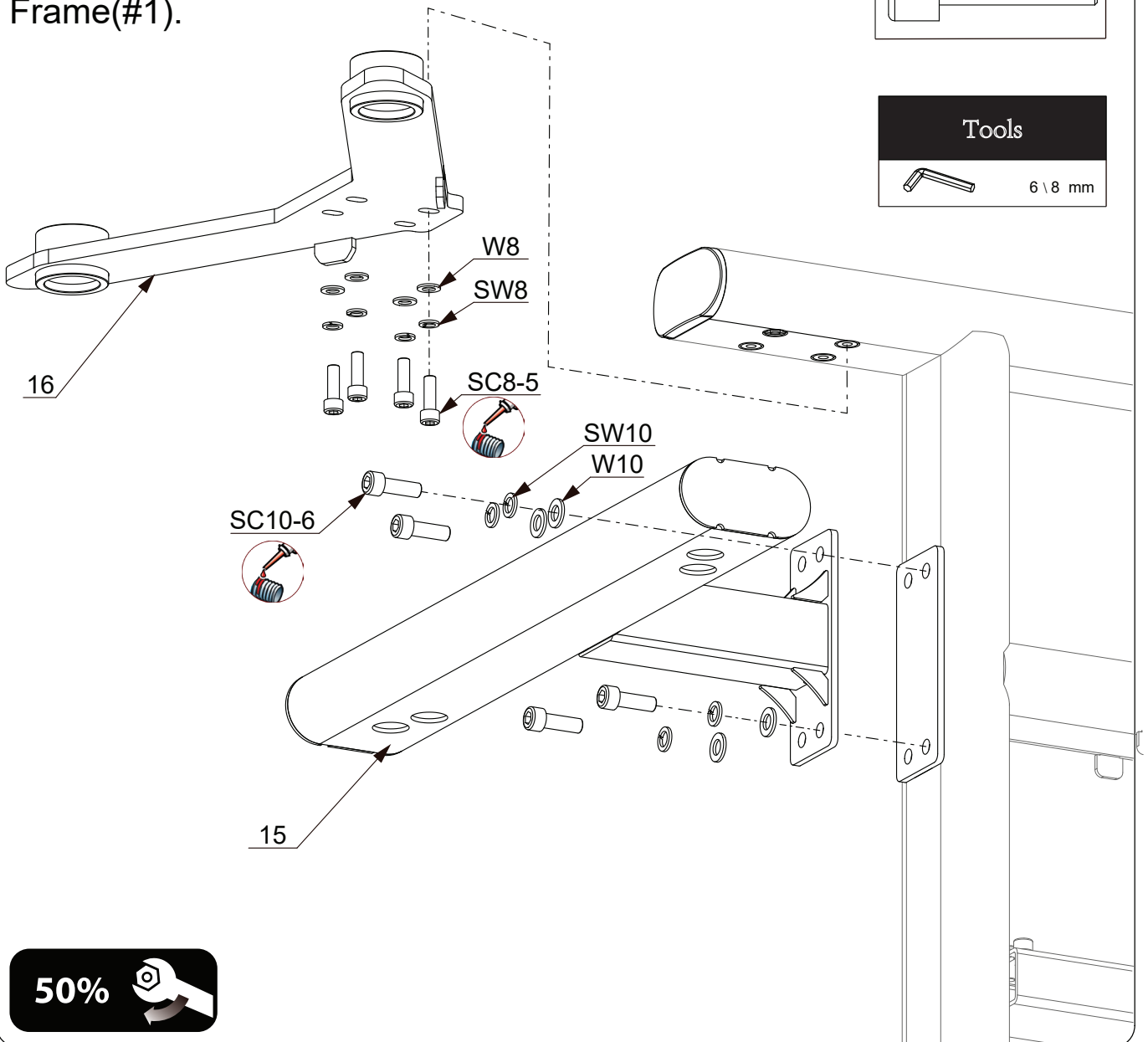

50%

STEP 6

Tools

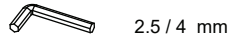

2.5 / 4 mm

Fixings

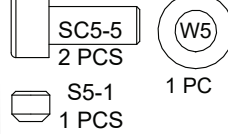

SC5-5
2 PCS



W5
1 PC

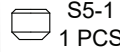

S5-1
1 PCS

Parts

Part No:17

Name: Upper Arm

Q'TY:1

Part No:18

Name: Cam 1

Q'TY:1

Part No:21

Name: Mounted Bearing

Q'TY:1

Part No:22

Name: Shaft

Q'TY:1

Part No:23

Name: Big Washer OD37

Q'TY:1

Part No:24

Name: Wave Washer

Q'TY:1

Assemble the Upper Arm(#17) ,
Cam 1(#18) ,Shaft(#22),Mounted
Bearing(#21),Big Washer(#23)
and the Wave Washer(#24).

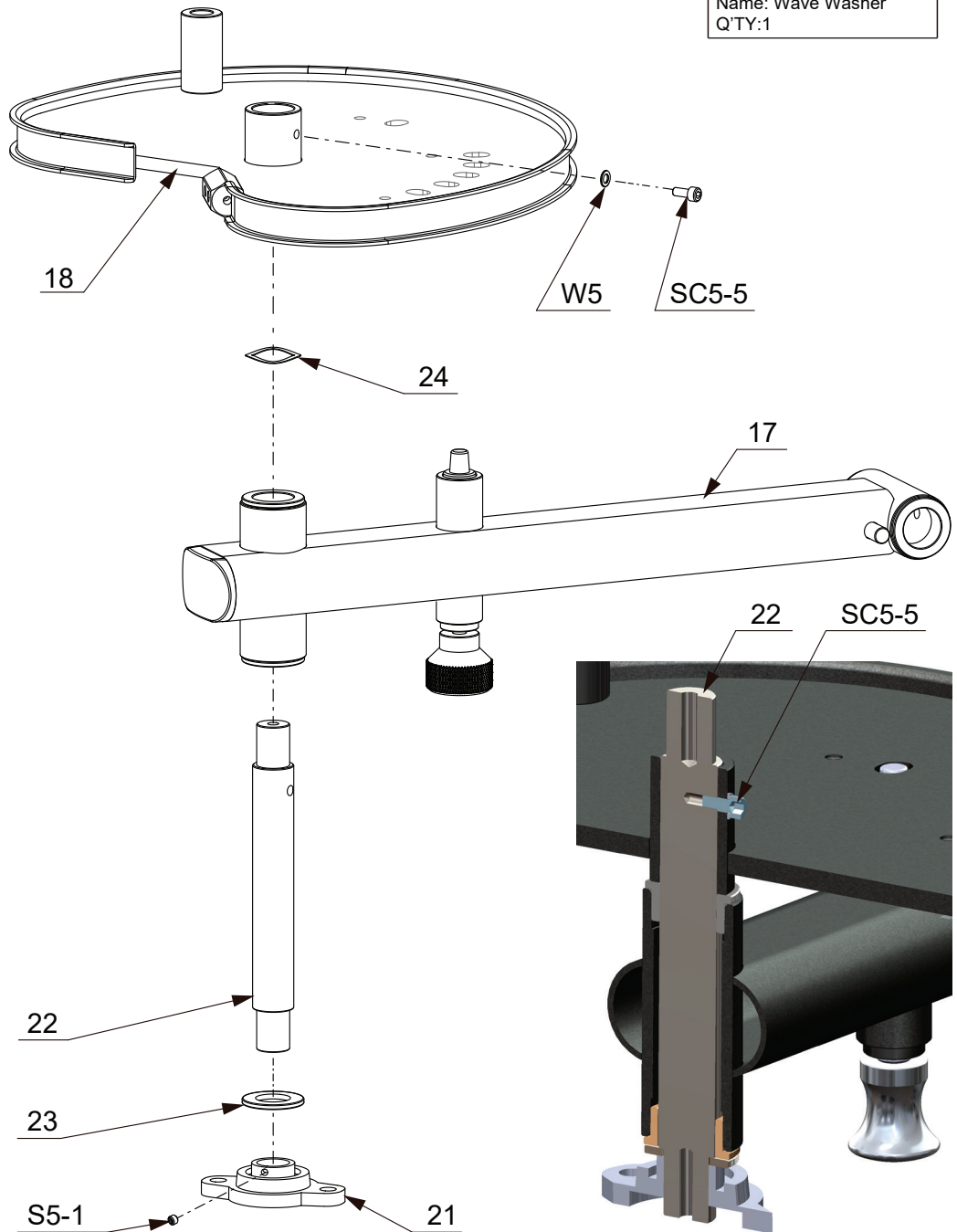
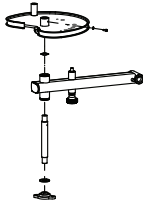
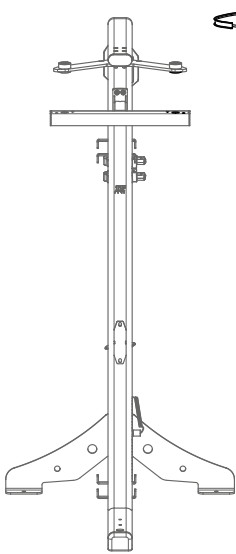



50%



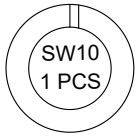

STEP 7

Parts	
Part No:20	
Name: D25 Hole Cap	
Q'TY:2	

Fixings	
SC10-6 2 PCS	 SW10 1 PCS
	 N10 1 PCS
	 W10 2 PCS

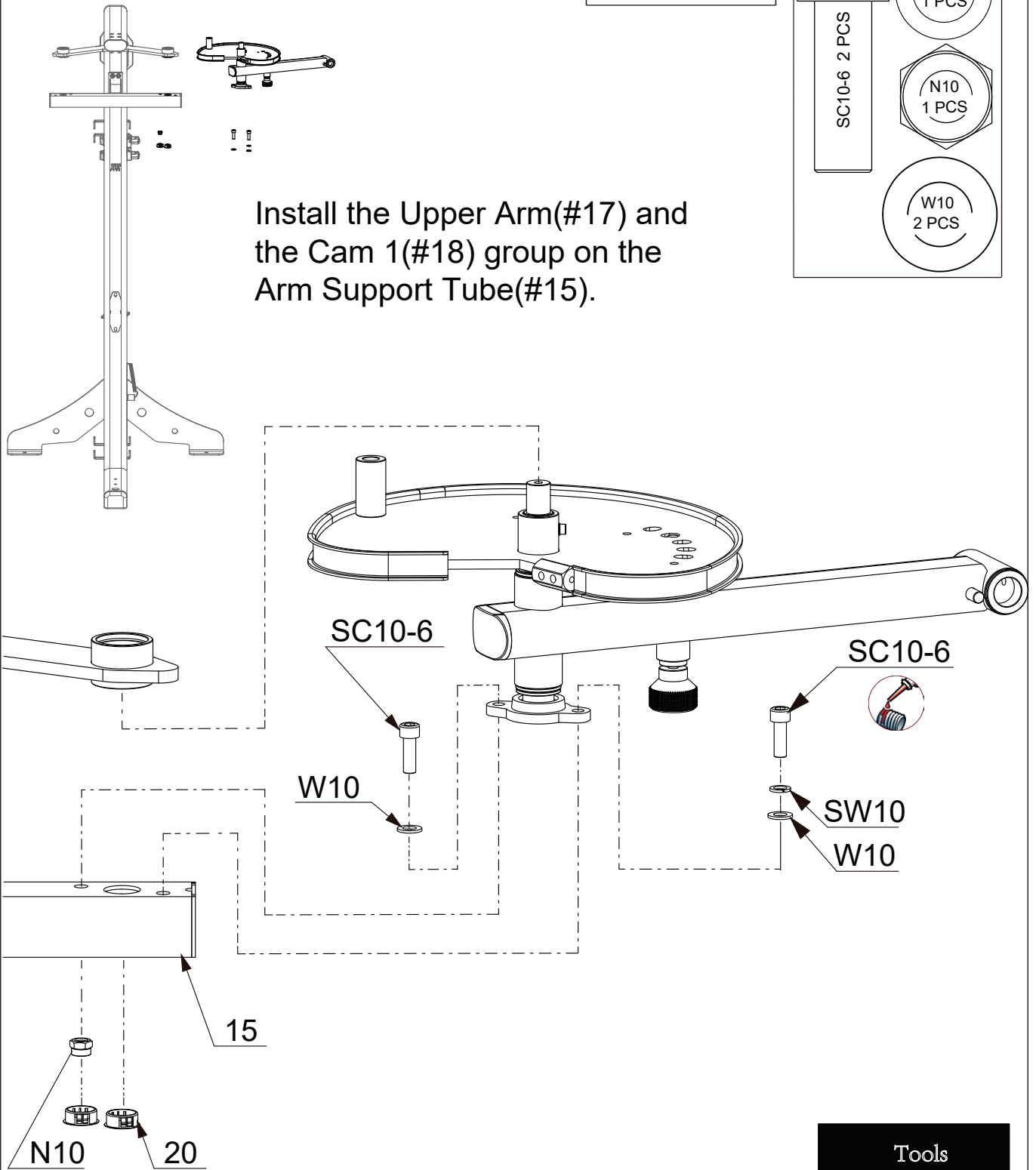
Install the Upper Arm(#17) and the Cam 1(#18) group on the Arm Support Tube(#15).



Tools	
	17 mm
	8 mm



STEP 8

Tools

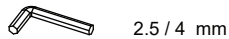

2.5 / 4 mm

Fixings

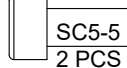

SC5-5
2 PCS



W5
1 PC

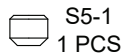

S5-1
1 PCS

Parts

Part No:17
Name: Upper Arm
Q'TY:1



Part No:19
Name: Cam 2
Q'TY:1

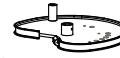

Part No:21
Name: Mounted Bearing
Q'TY:1



Part No:22
Name: Shaft
Q'TY:1

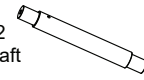

Part No:23
Name: Big Washer OD37
Q'TY:1



Part No:24
Name: Wave Washer
Q'TY:1



Assemble the Upper Arm(#17) ,
Cam 2(#19) ,Shaft(#22),Mounted
Bearing(#21),Big Washer(#23)
and the Wave Washer(#24).

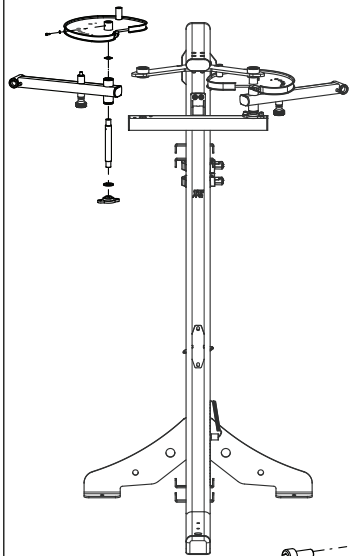

SC5-5

W5

18

24

17

SC5-5

22

22

23

21

S5-1

50%



STEP 9

Parts

Part No:20
Name: D25 Hole Cap
Q'TY:2



Tools



17 mm



8 mm

Fixings

SC10-6 2 PCS

SW10
1 PCS

N10
1 PCS

W10
2 PCS

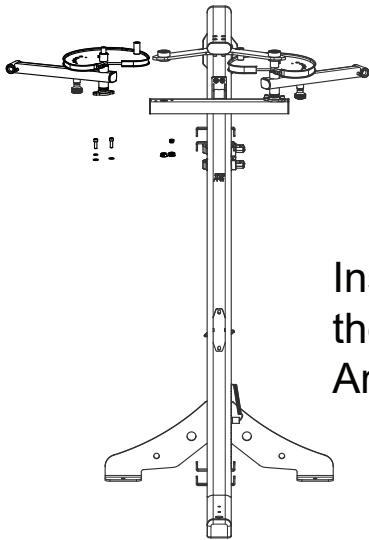

Install the Upper Arm(#17) and the Cam 2(#19) group on the Arm Support Tube(#15).

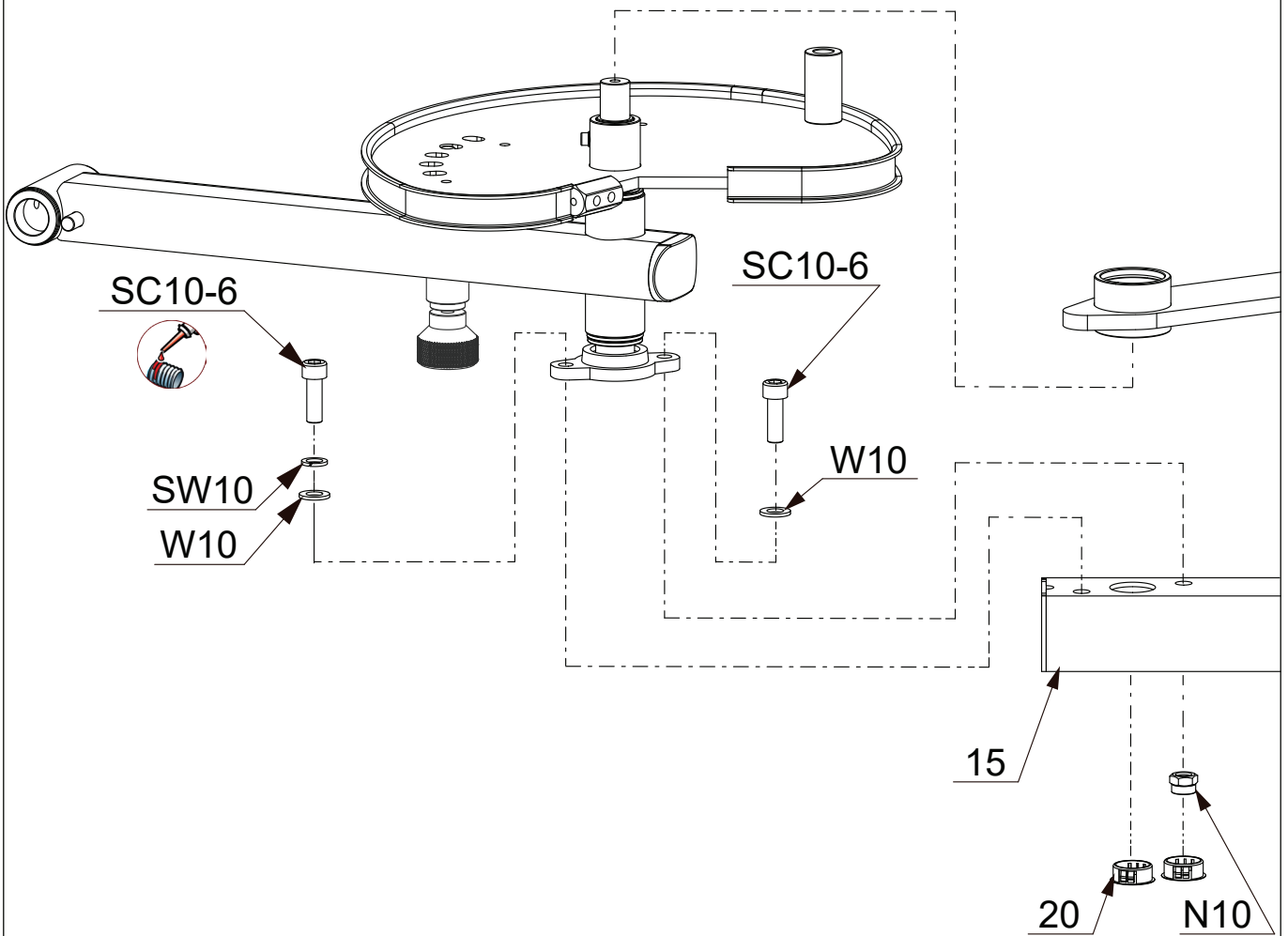

50%



STEP 10

Tools



6 mm

Parts

Part No:25
Name: Internal Retaining Ring
Q'TY:2



Part No:26
Name: Bearing 6004
Q'TY:4



Fixings



SC8-3
2 PCS



SW8
2 PCS

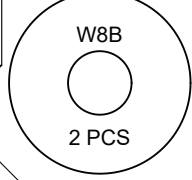

W8B
2 PCS

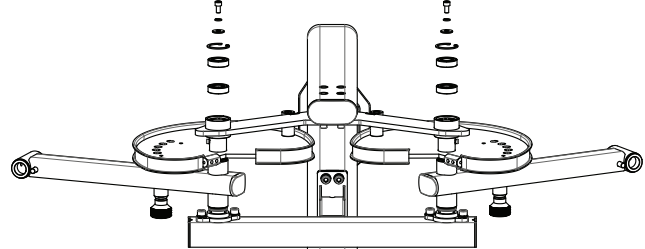

Install the Bearings(#26) to the Arm Support Plate(#16).

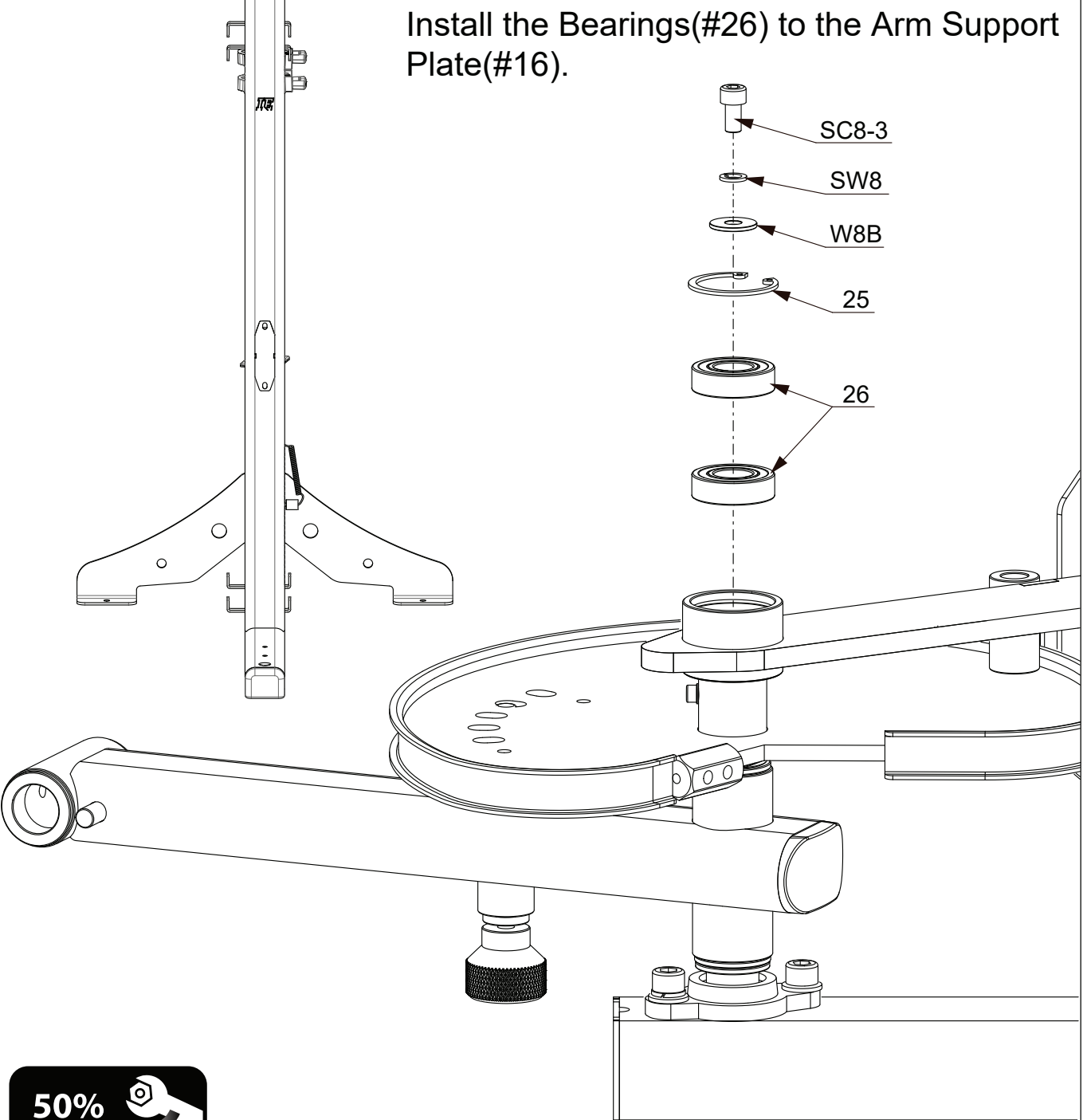

50% 

STEP 11

Tools



8 mm

Parts

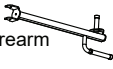
Part No:27  Name: Left Forearm Q'TY:1

Part No:28  Name: Right Forearm Q'TY:1

Part No:29  Name: Shaft OD25x83.5 Q'TY:2

Fixings

W10
4 PCS

SC10-5 4PCS

Install The Left Forearm(#27) And The Right Forearm(#28).

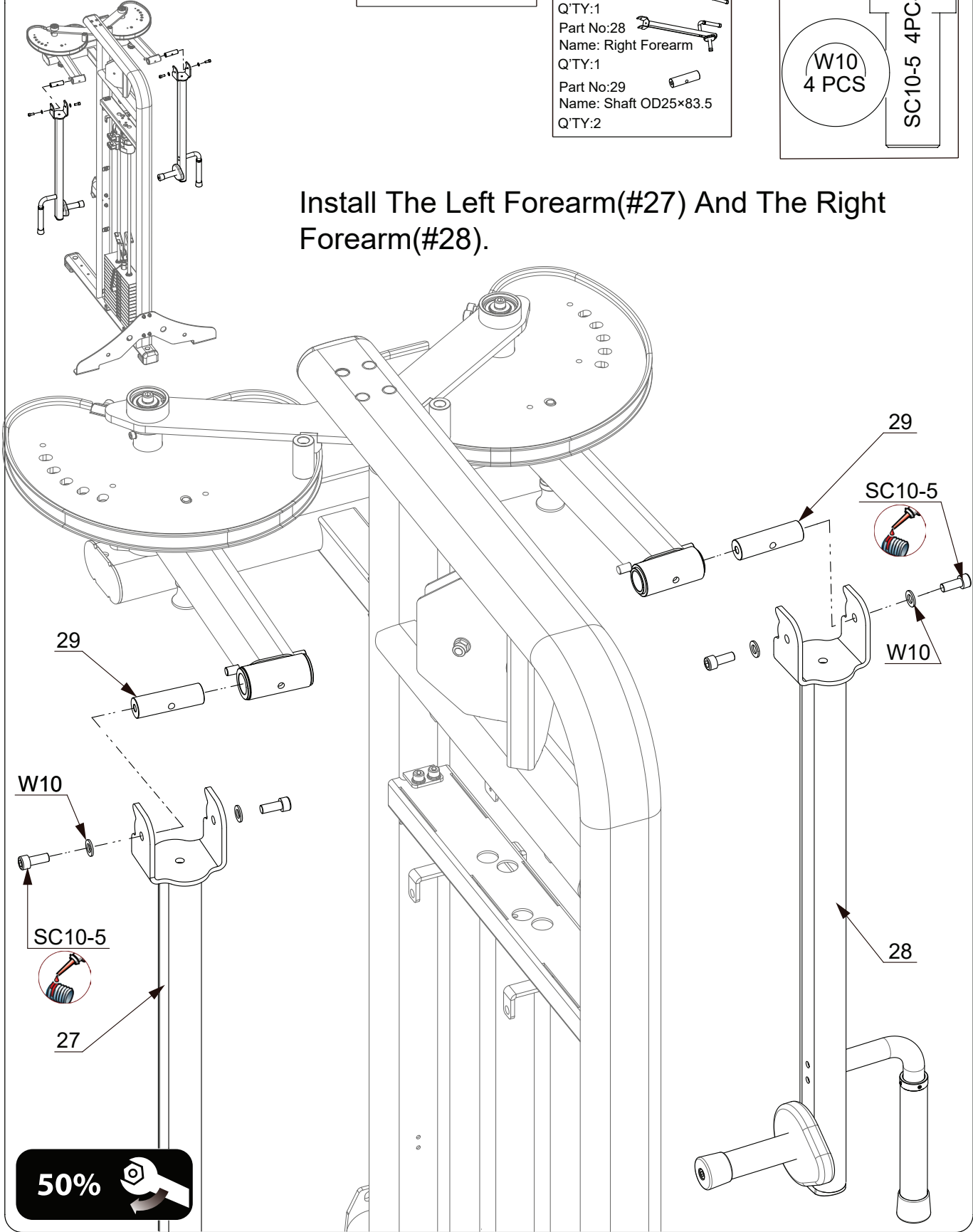

50% 

STEP 12

Route the Cable(#30).
Screw both-side cable ends
by bolts(SC8-3).

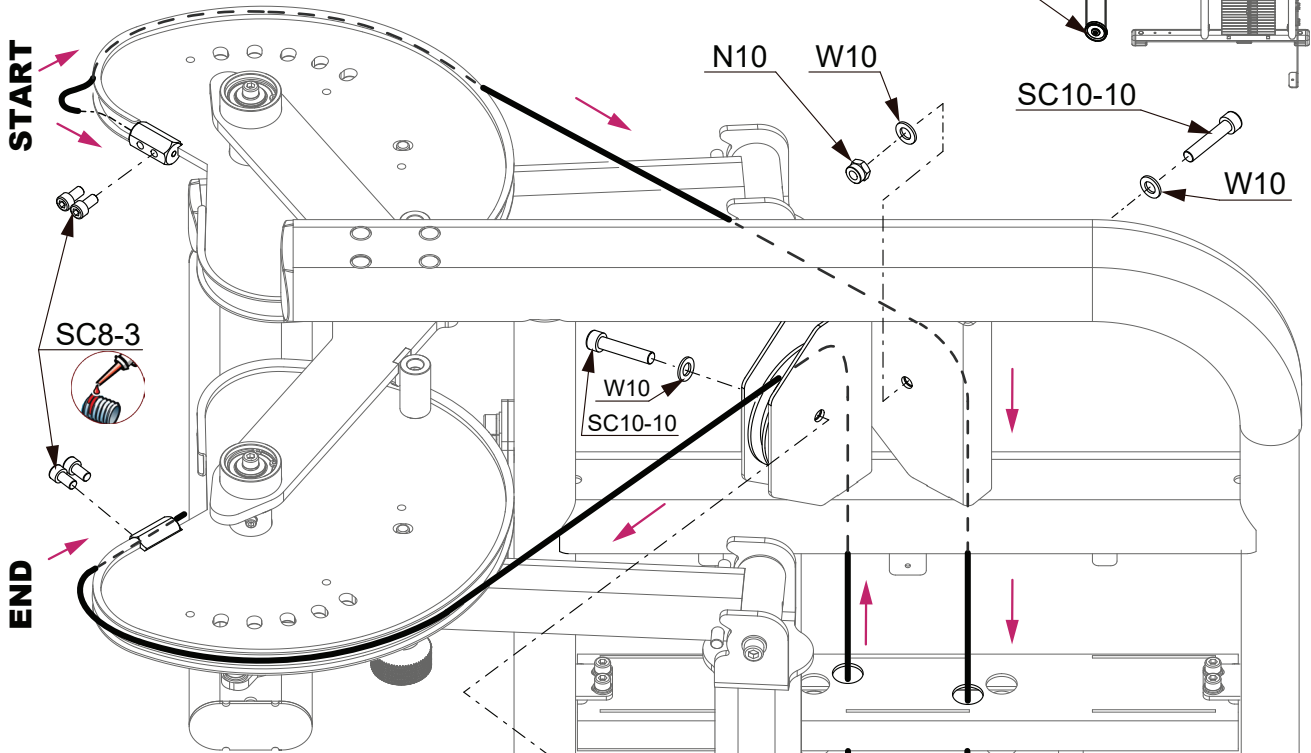

Fixings	Parts
N10 3PCS	Part No:30 Name: Cable Q'TY:1 Part No:31 Name: Pulley Q'TY:3
SC8-3 4PCS	
SC10-10 3 PCS	
W10 6 PCS	Tools 6 \ 8 mm

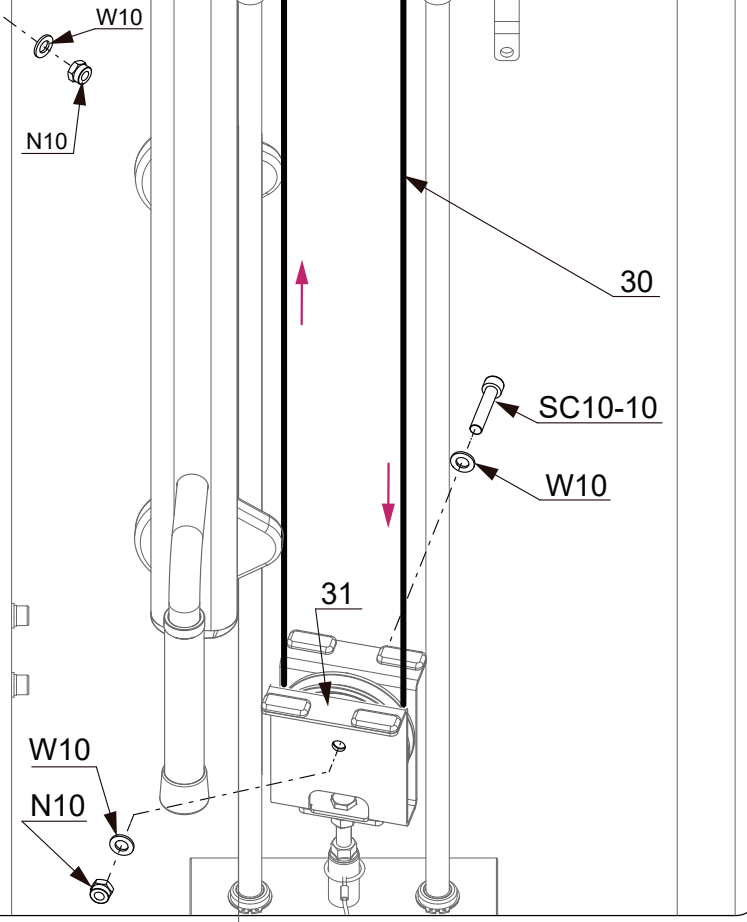

EXTERIOR ADJUSTMENT

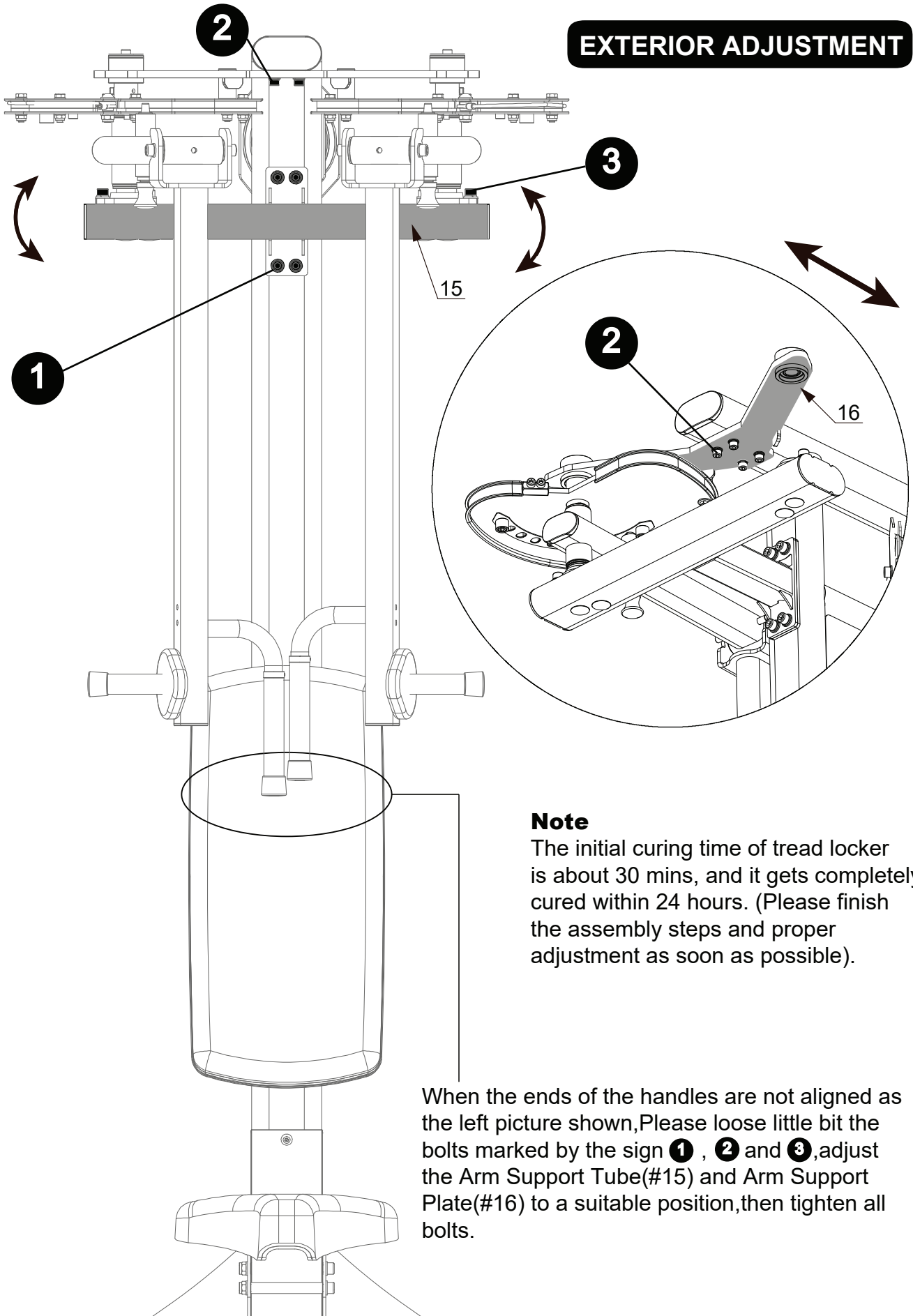

Note

The initial curing time of tread locker is about 30 mins, and it gets completely cured within 24 hours. (Please finish the assembly steps and proper adjustment as soon as possible).

When the ends of the handles are not aligned as the left picture shown, Please loose little bit the bolts marked by the sign ① , ② and ③, adjust the Arm Support Tube(#15) and Arm Support Plate(#16) to a suitable position, then tighten all bolts.

EXTERIOR ADJUSTMENT

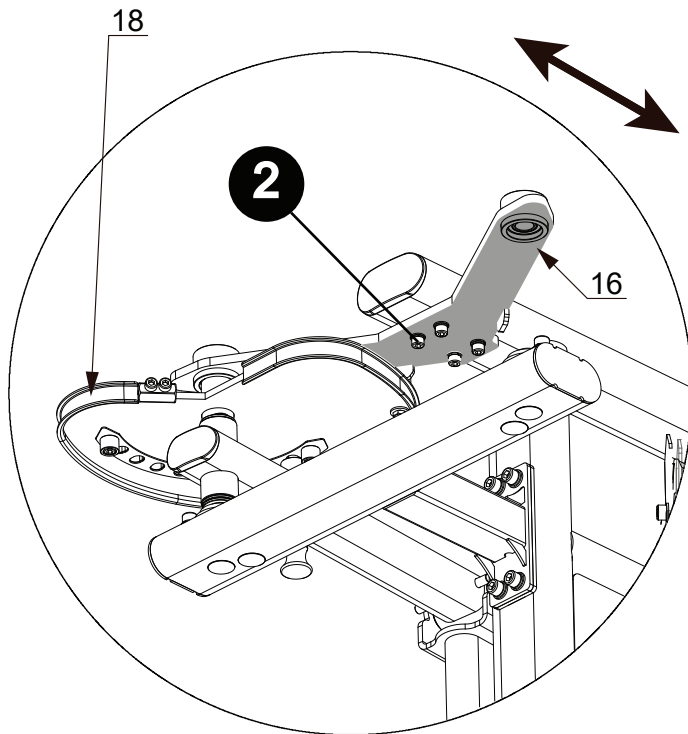
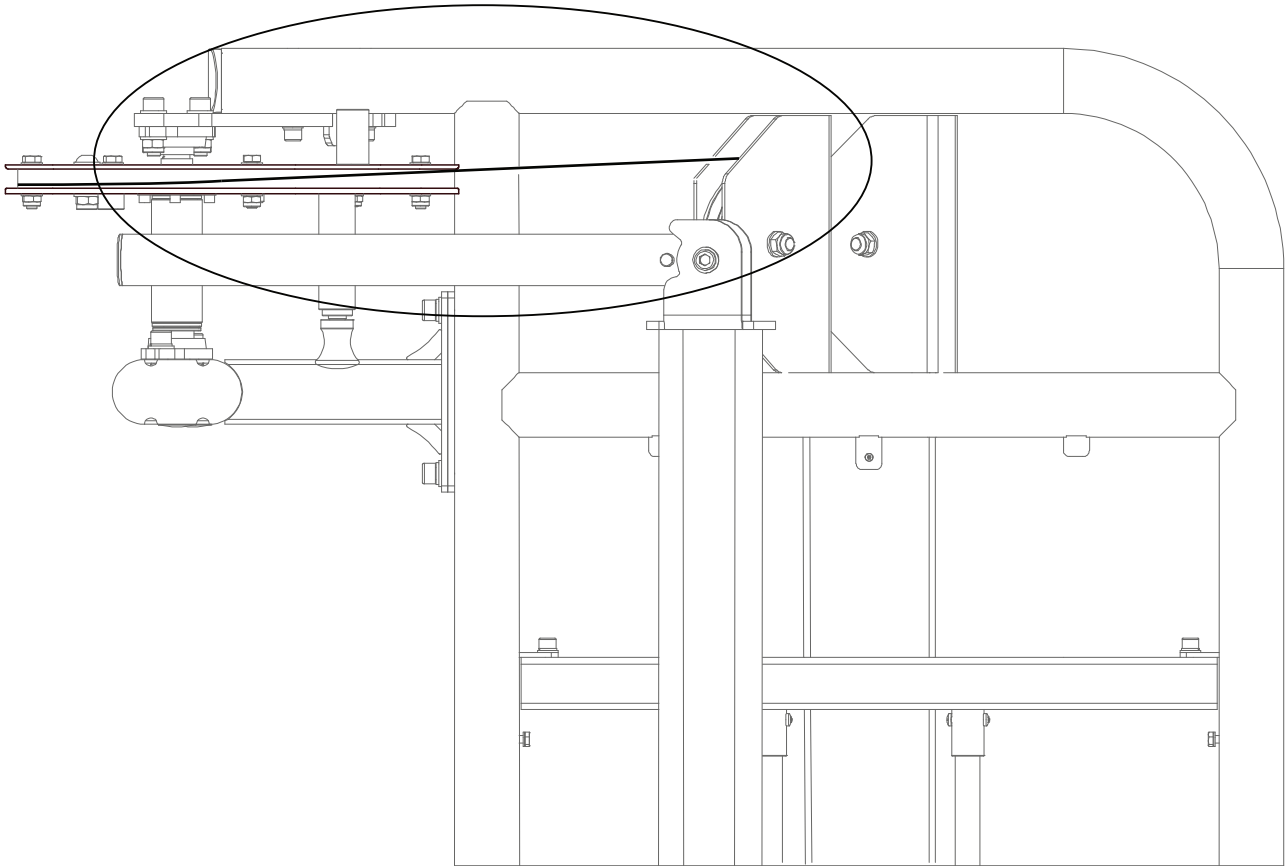

When the Cable(#30) isn't in the groove of the Cam 1(#18) or Cam 2(#19),Loose the bolts marked by the sign **2** ,adjust the Arm Support Plate(#16) to a suitable position,then tighten all bolts.

STEP 13

Fixings

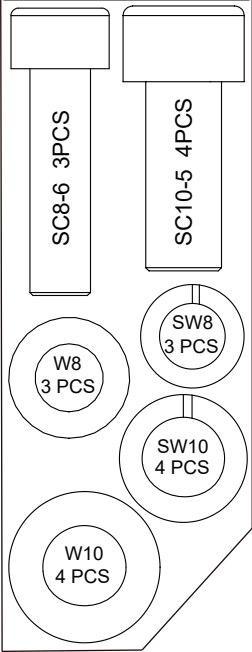

Parts

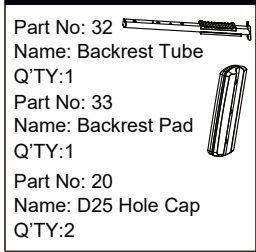

Tools



Install the Backrest Tube(#32) and the Backrest Pad(#33).

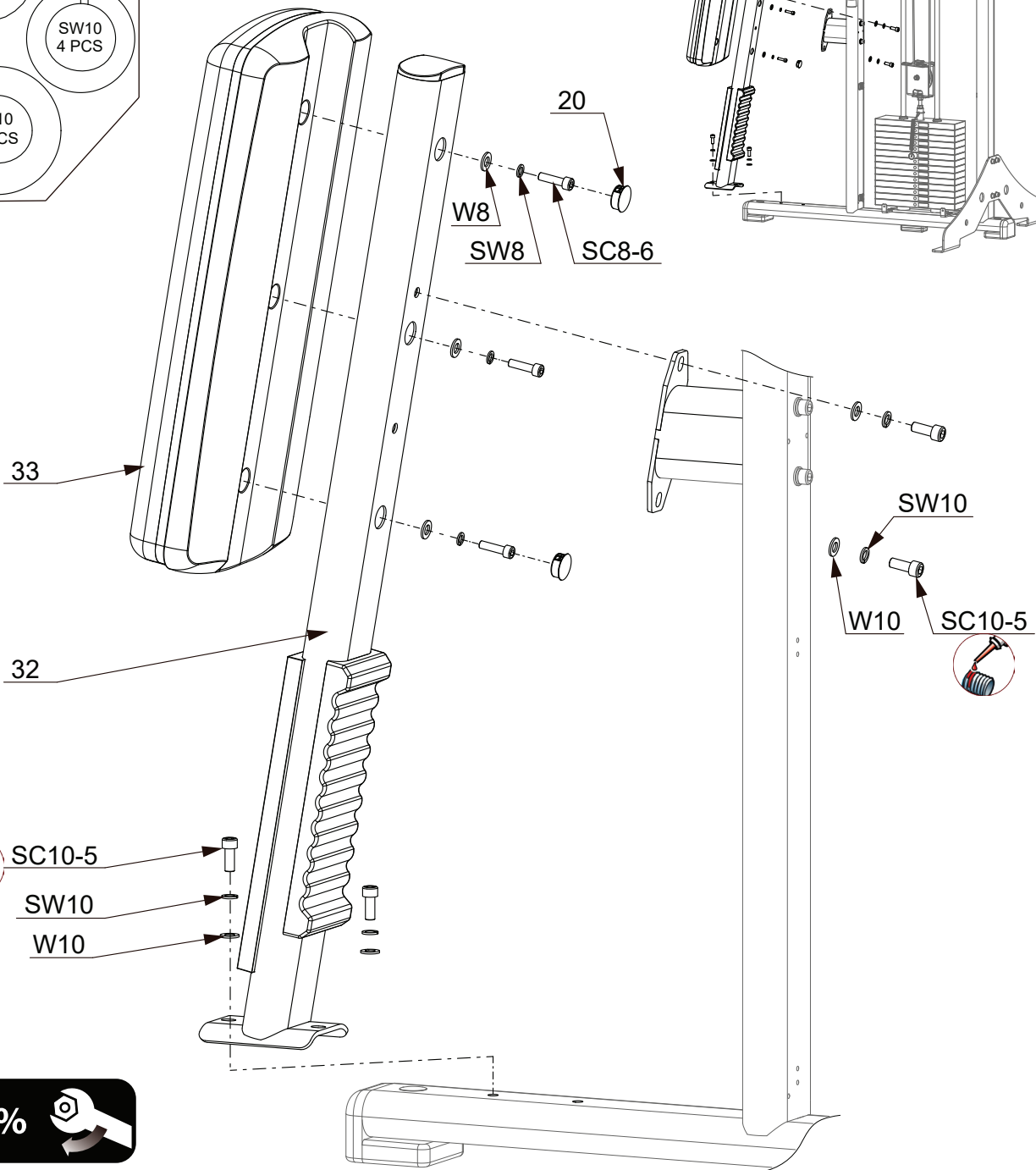
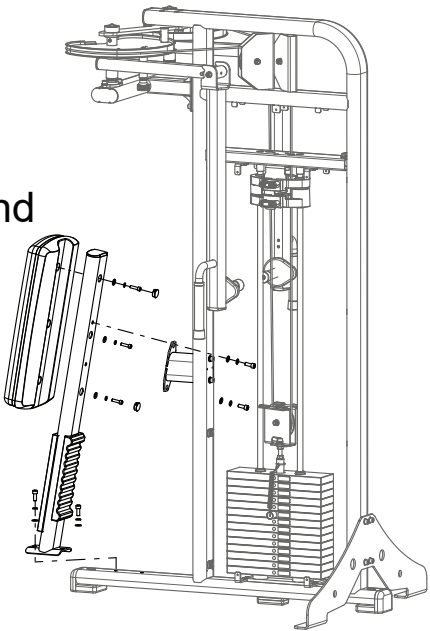

STEP 14

Install the Seat Frame(#34) and the Seat Pad(#35).

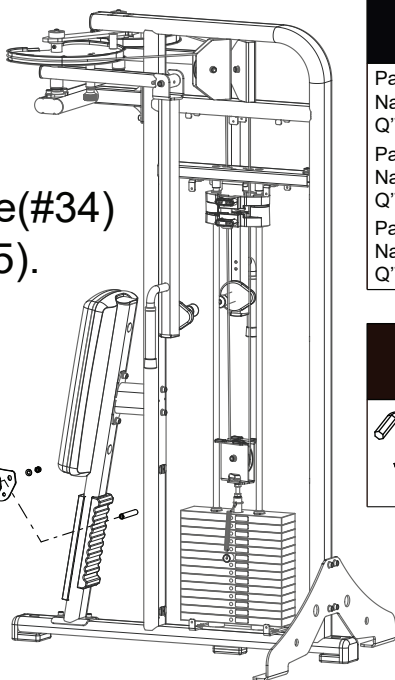

Parts	
Part No: 34	
Name: Seat Frame	
Q'TY: 1	
Part No: 35	
Name: Seat Pad	
Q'TY: 1	
Part No: 36	
Name: Sleeve	
Q'TY: 1	

Tools	
	6 \ 8 mm
	17 mm

Fixings	
	SC8-6 4PCS
	SC10-25 4PCS
	W8 4 PCS
	N10 1 PC
	W10 2 PCS

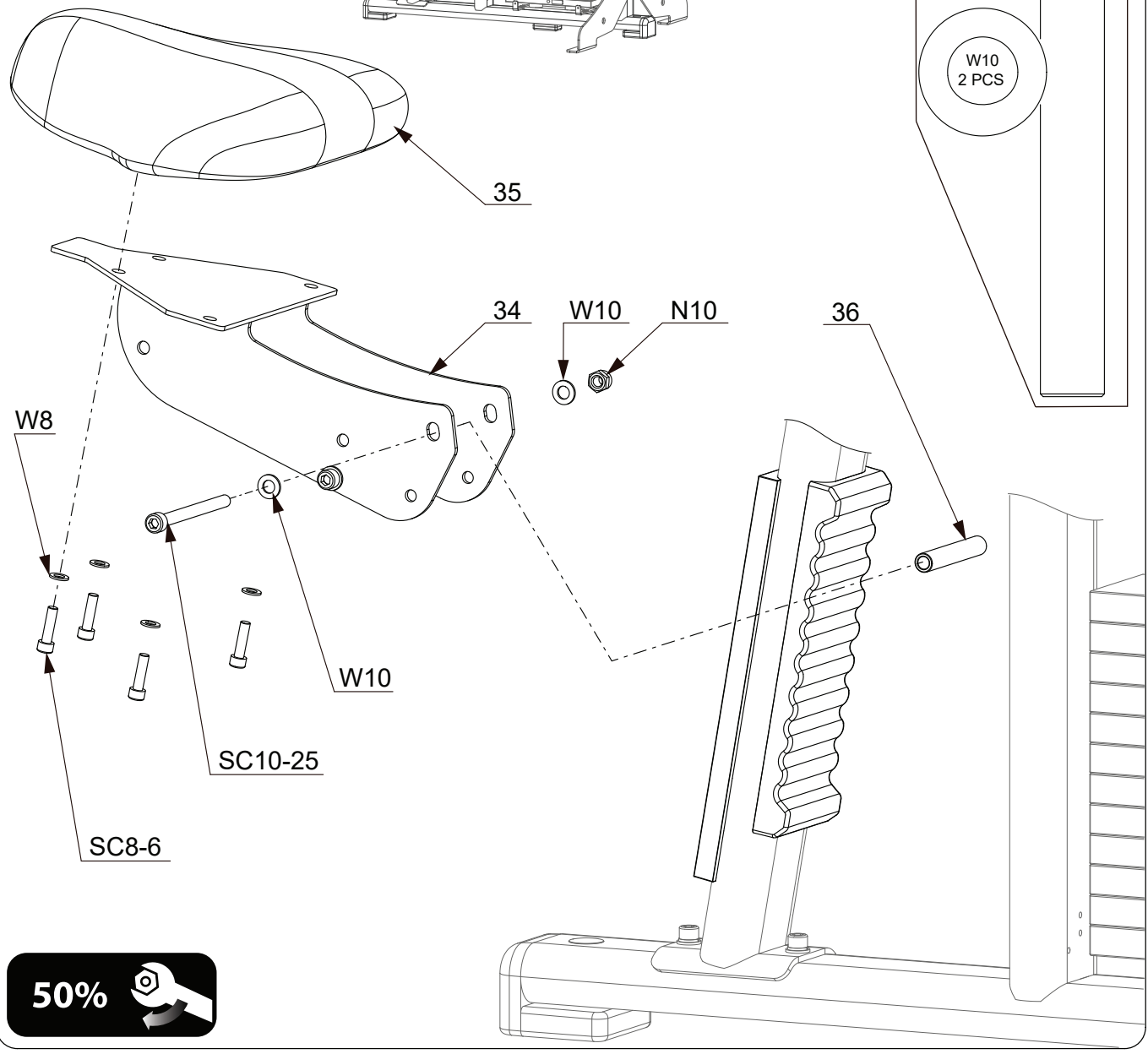

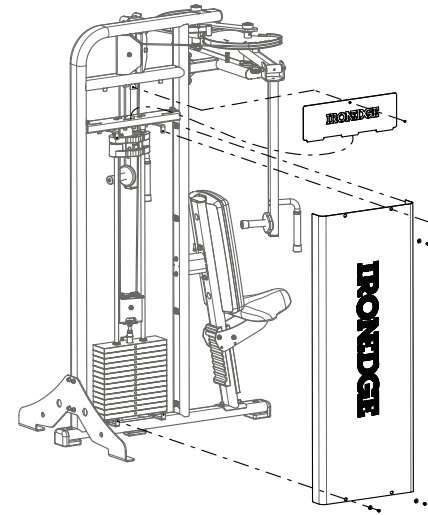
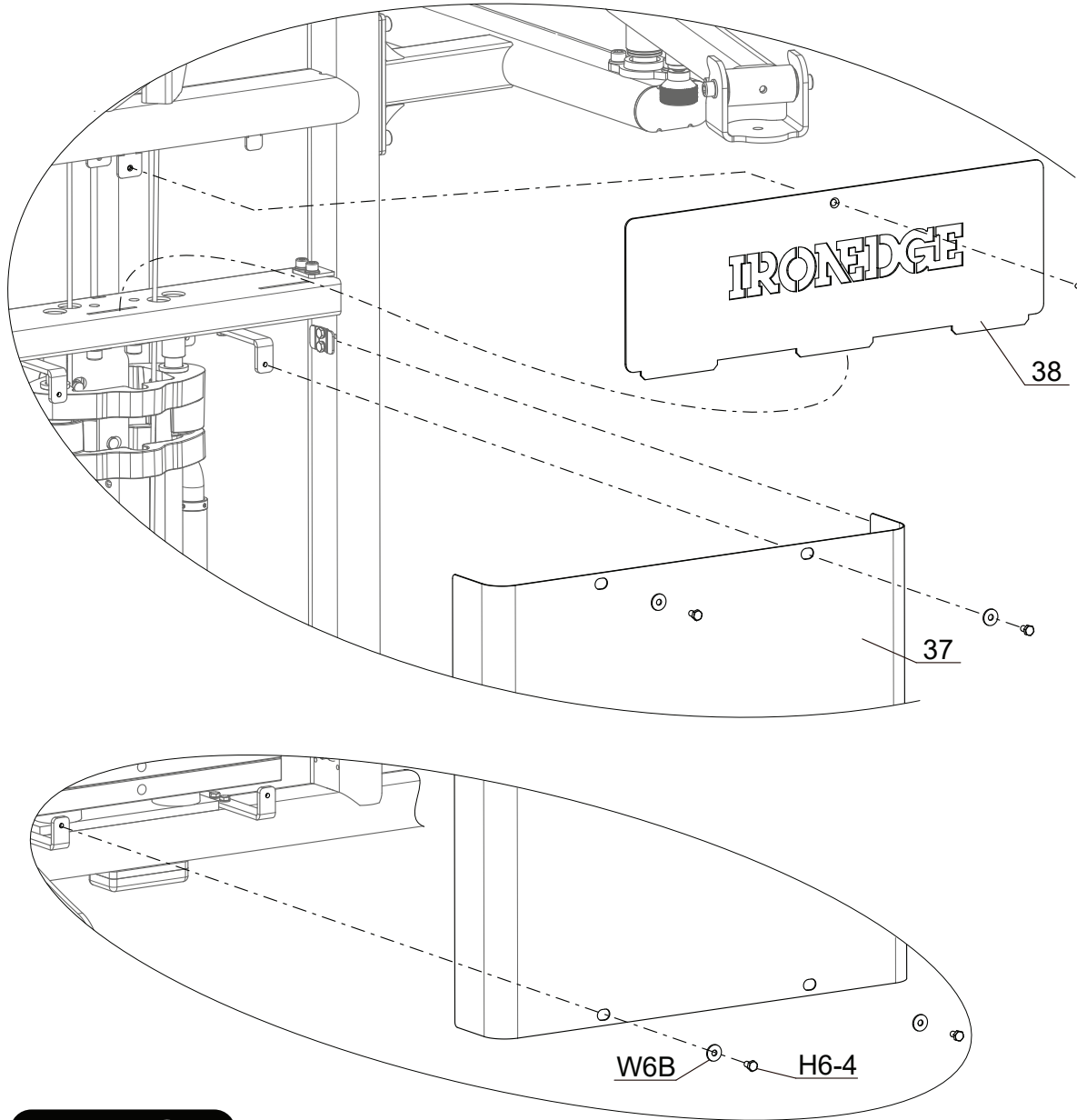





STEP 15

Install the Back Lower Shield(#37) and the Back Upper Shield(#38).

Parts

- Part No: 37 
Name: Back Lower Shield
Q'TY:1
- Part No: 38 
Name: Back Upper Shield
Q'TY:1

Fixings

- 
W6B
4 PCS
- 
H6-4
4 PCS
- 
C5-4
1 PC

Tools

-  10 mm
-  3 mm

50% 

STEP 16

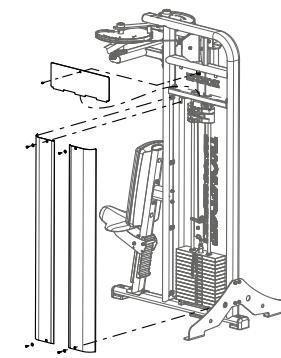
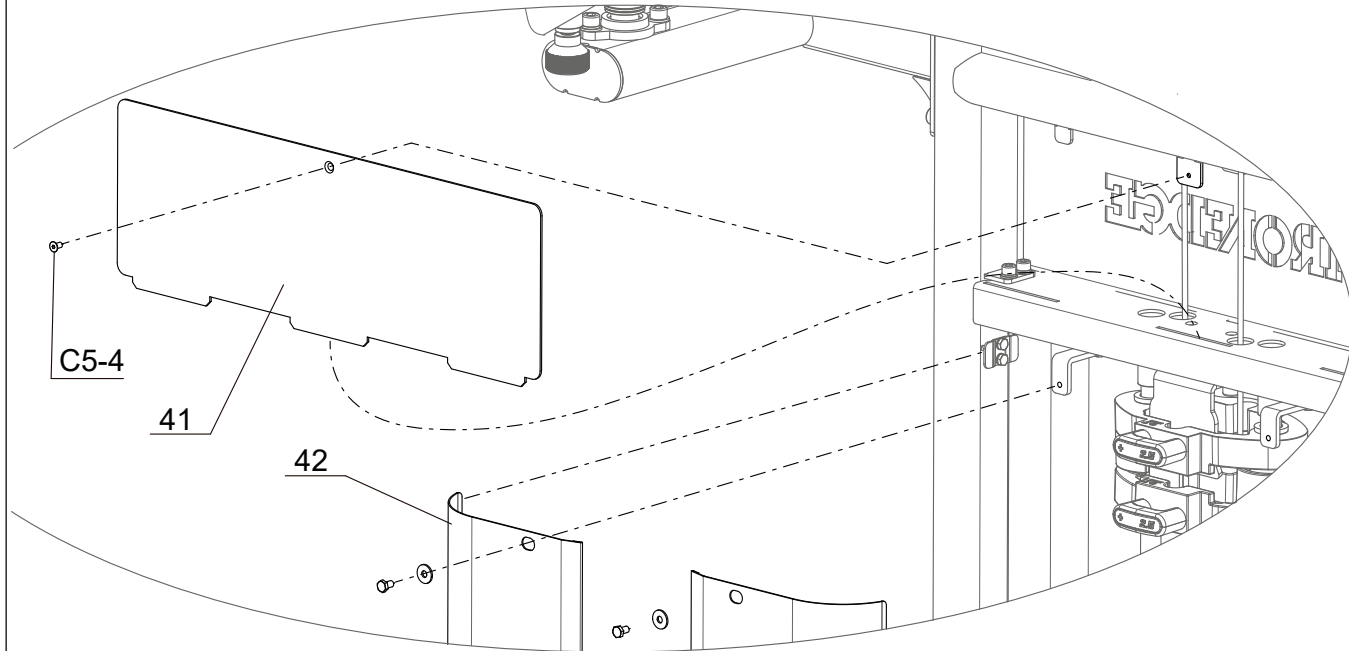

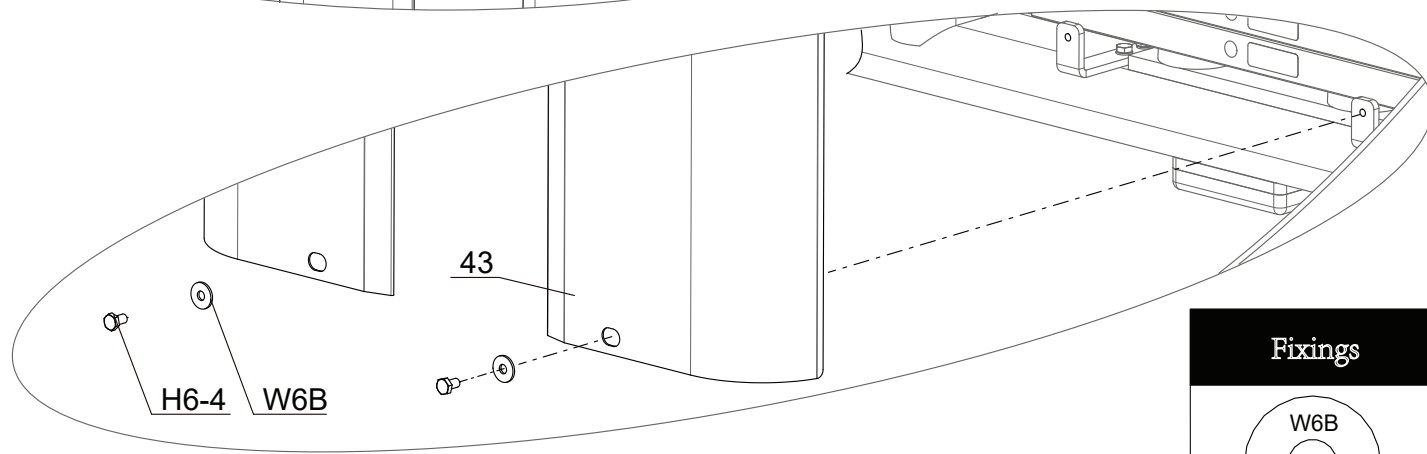

Install The Front Lower Shield (#42 & #43) and The Upper Shield(#41).





Tools

-  10 mm
-  3 mm

Parts

- Part No: 41  Name: Upper Shield Q'TY:1
- Part No: 42  Name: Front Lower Shield Q'TY:1
- Part No: 43  Name: Front Lower Shield Q'TY:1

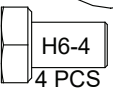
Fixings

-  W6B
4 PCS
-  H6-4
4 PCS
-  C5-4
1 PC

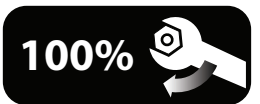

PARTS LIST

PART #	DESCRIPTION	QTY
1	Main Frame	1
2	Plate Brace	1
3	U Plate	4
4	Link Tube	4
5	Guide Rod	2
6	Rubber Buffer	2
7	Holding Plate	1
8	Weight Label	1
9	Weight Plate 7.5 Kg	14
10	Weight Pin	1
11	Top Weight Plate	1
12	Pulley Holder	1
13	External Retaining Ring	2
14	Rod Retainer	2
15	Arm Support Tube	1
16	Arm Support Plate	1
17	Upper Arm	2
18	Cam 1	1
19	Cam 2	1
20	D25 Hole Cap	6
21	Mounted Bearing	2
22	Shaft	2
23	Big Washer OD37	2
24	Wave Washer	2
25	Internal Retaining Ring	2
26	Bearing 6004	4
27	Left Forearm	1
28	Right Forearm	1
29	Shaft OD25×83.5	2
30	Cable	1
31	Pulley	3
32	Backrest Tube	1
33	Backrest Pad	1
34	Seat Frame	1
35	Seat Pad	1
36	Sleeve	1
37	Back Lower Shield	1
38	Back Upper Shield	1
39	Micro Weight Adjuster	2
40		
41	Front Upper Shield	1
42	Front Lower Shield	1
43	Front Lower Shield	1
C5-4	Countersunk Head Screw M5 x 10	2
N10	Lock Nut M10	6

PART #	DESCRIPTION	QTY
H6-4	Hex Head Bolt M6 x 10	16
S8-7	Socket Set Screw M8 x 35	2
SC5-5	Socket Head Cap Screw M5 x 12	2
SC8-3	Socket Head Cap Screw M8 x 15	6
SC8-5	Socket Head Cap Screw M8 x 25	4
SC8-6	Socket Head Cap Screw M8 x 30	7
SC10-5	Socket Head Cap Screw M10 x 25	14
SC10-6	Socket Head Cap Screw M10 x 30	8
SC10-10	Socket Head Cap Screw M10 x 50	3
SC10-16	Socket Head Cap Screw M10 x 80	2
SC10-25	Socket Head Cap Screw M10 x 125	1
SW8	Spring Washer 8	9
SW10	Spring Washer 10	14
W5	Washer 5	2
W6	Washer 6	8
W8	Washer 8	11
W6B	Big Washer 6	8
W8B	Big Washer 8	2
W10	Washer 10	32