

**IRONEDGE.**

# Reverse Hyper Unilateral

## Setup Instructions

 CAUTION: Read all precautions and instructions before using this equipment. Save this manual for future reference.



# Table Of Contents

Assembly Instructions.....	2-11
Part List.....	12

# STEP 1

Assemble The  
Bottom Tube Assy(#1)  
And One Inclined  
Support Tube(#2) .

## Tools



30 mm

## Parts

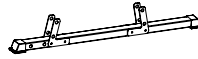

Part No: 1  
Name: Bottom Tube Assy  
Q'TY: 2

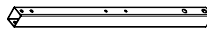

Part No: 2  
Name: Inclined Support  
Tube  
Q'TY: 2

## Fixings

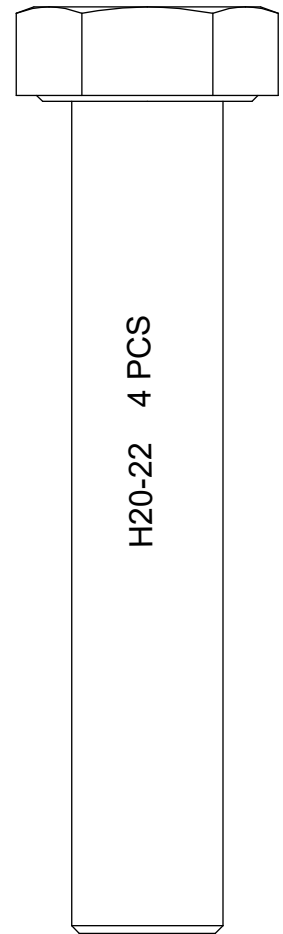

H20-22 4 PCS

## Fixings



N20  
4 PCS

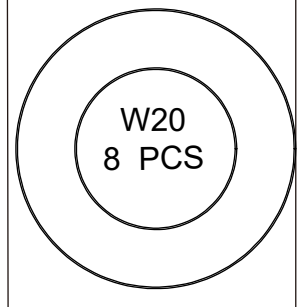

W20  
8 PCS

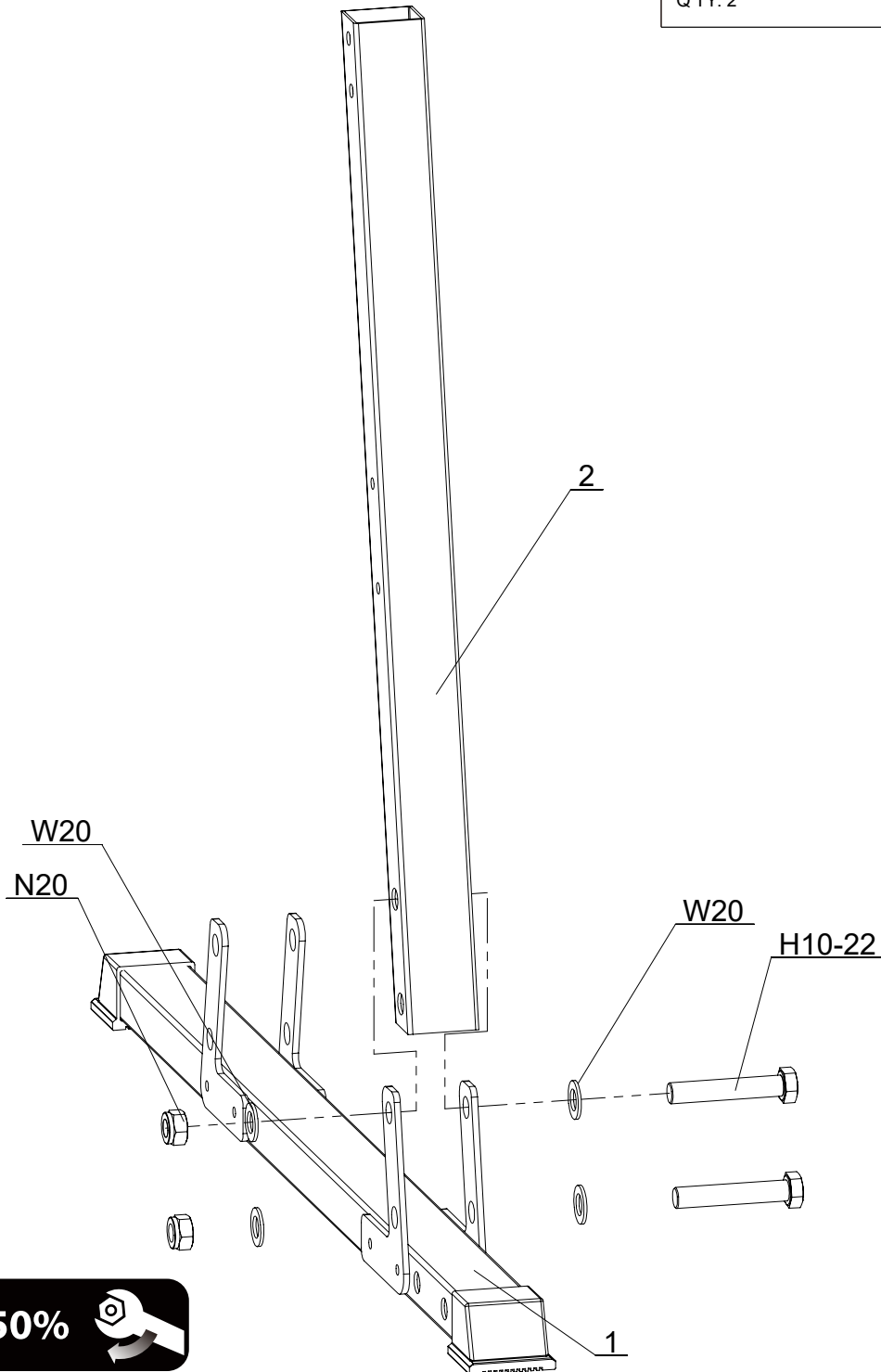

50%



# STEP 2

## Tools



30 mm

## Parts

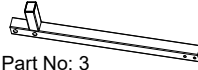

Part No: 3  
Name: Rear Inclined  
Support Tube  
Q'TY: 1

## Fixings

### Fixings

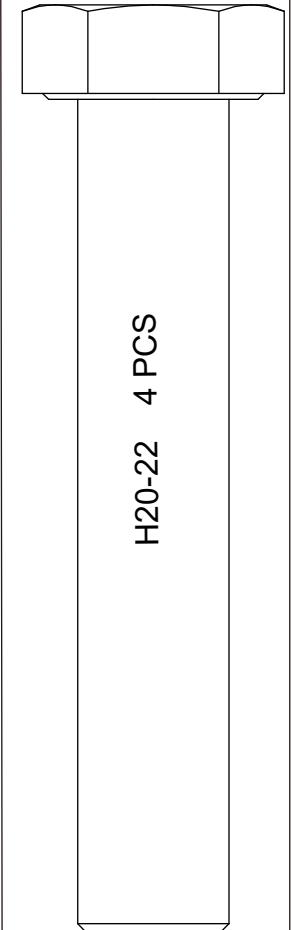
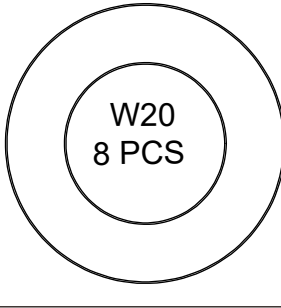
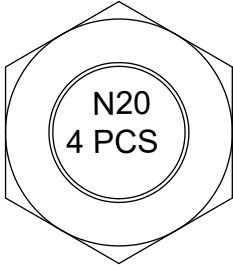

Install The Rear Inclined  
Support Tube(#3).

*(Assemble The Other Side  
By The Same Way.)*

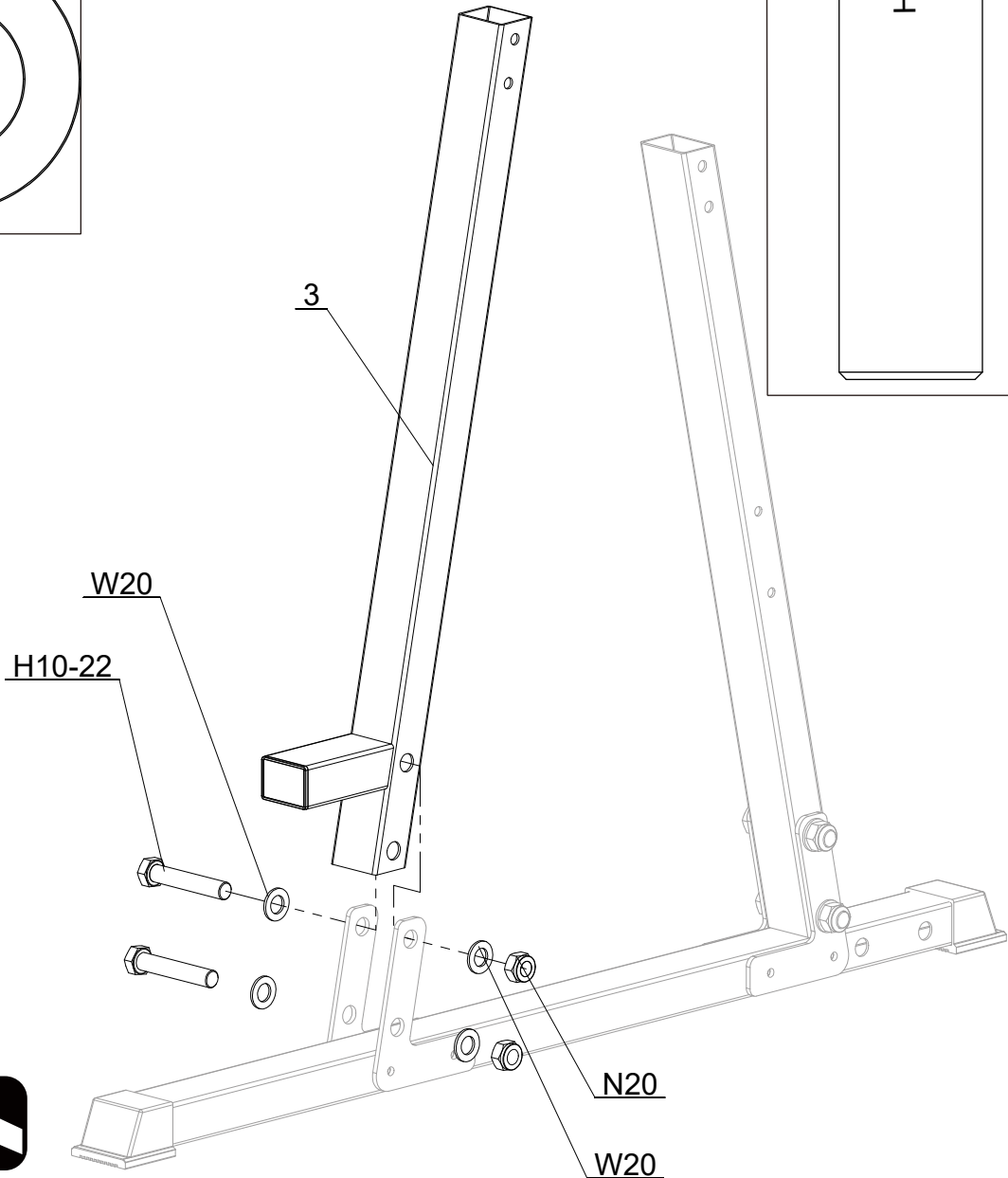

50%



# STEP 3

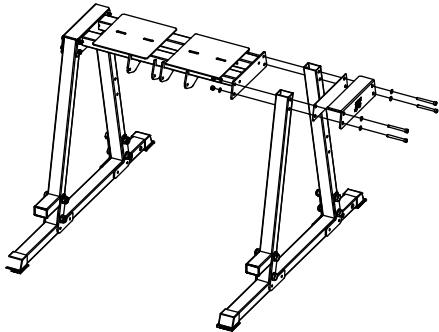

Assemble The Topframe(#4) & Side Bended Plate(#6) And The Backing Plate (#5)on The Main Frame,And The Same Way On The OAndther Side.

## Parts

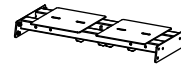

Part No: 4  
Name: Top Frame  
Q'TY: 1

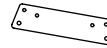

Part No: 5  
Name: Backing Plate  
Q'TY: 2



Part No: 6  
Name: Side Bended Plate  
Q'TY: 2

## Fixings



N10  
8 PCS

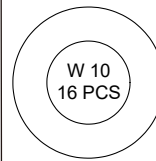

W 10  
16 PCS

SC10-19 8 PCS

## Tools



17 mm



8 mm

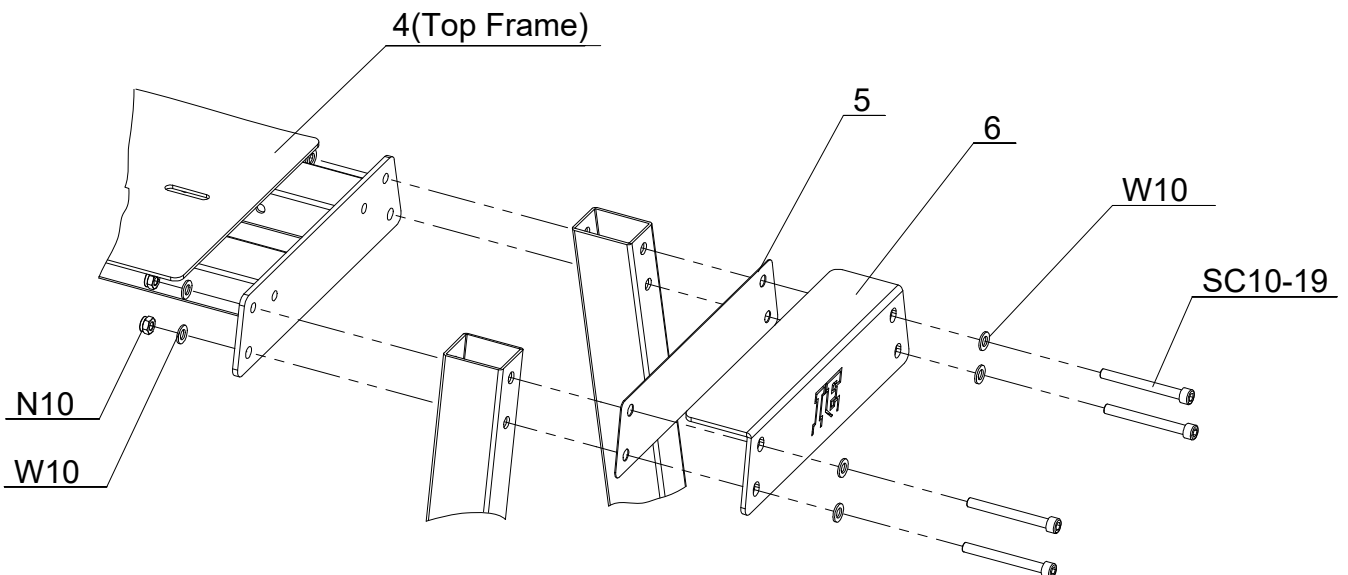

50%



# STEP 4

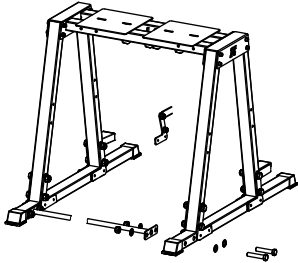

## Parts

  
Part No: 7  
Name: Bottom  
Lateral Tube Assy  
Q'TY: 1

## Tools

 17 / 30 mm

## Fixings

N20  
4 PCS

W20  
8 PCS

## Fixings

H20-20 4 PCS

Assemble The Bottom Lateral Tube Assy(#7).

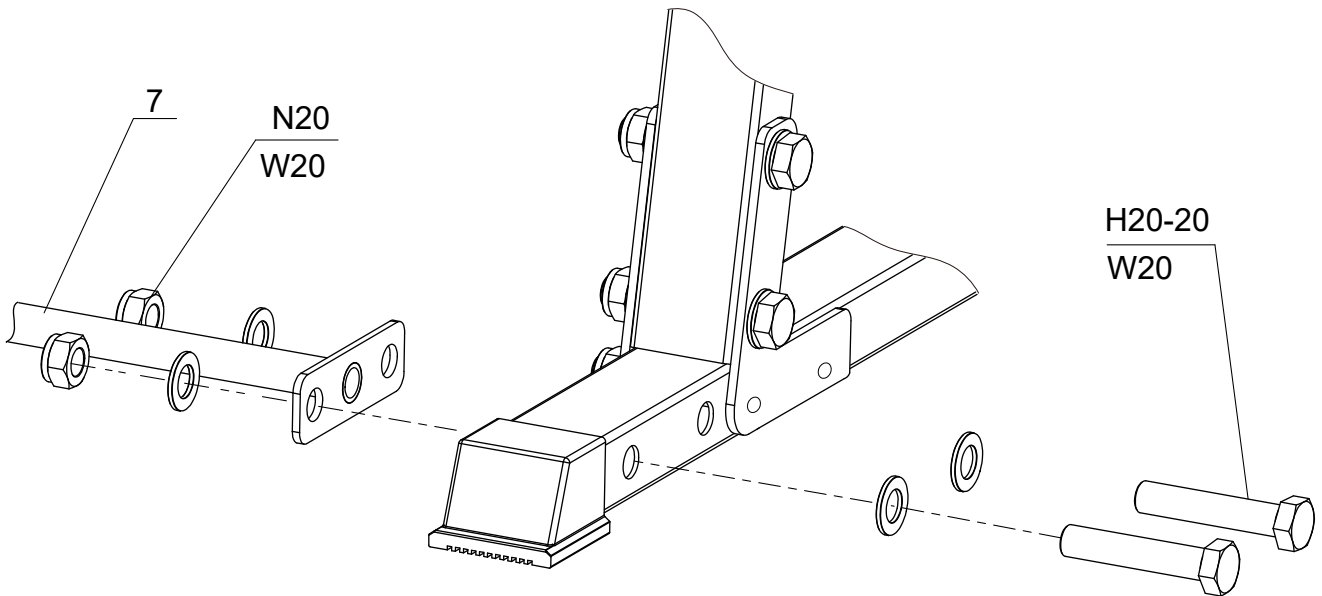

50%



# STEP 5

Assemble The Pendulum Arm(#9) And  
The Set Contained Bearing(#8).

## Parts



Part No: 9  
Name: Pendulum Arm  
Q'TY:2



Part No: 8  
Name: Set Contained  
Bearing  
Q'TY:4

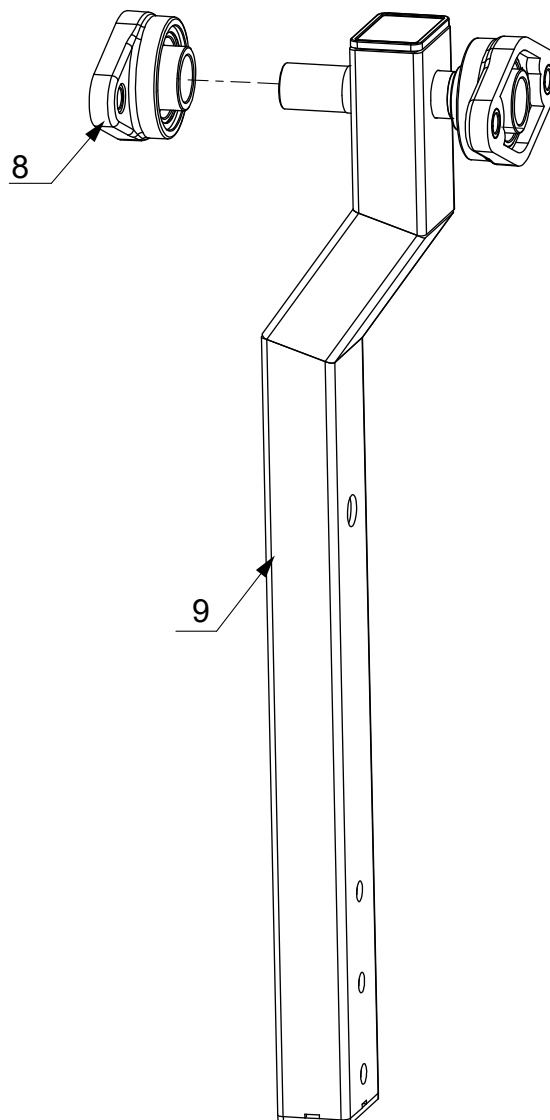

50%



# STEP 6

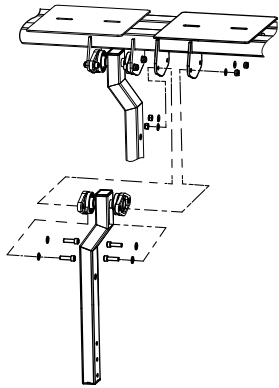

## Tools

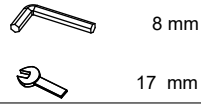

## Fixings

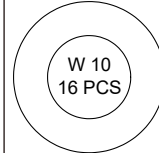

SC10-7 8 PCS

Fit The Pendulum Arm Group(#9 & #8) To Top Frame(#4) .

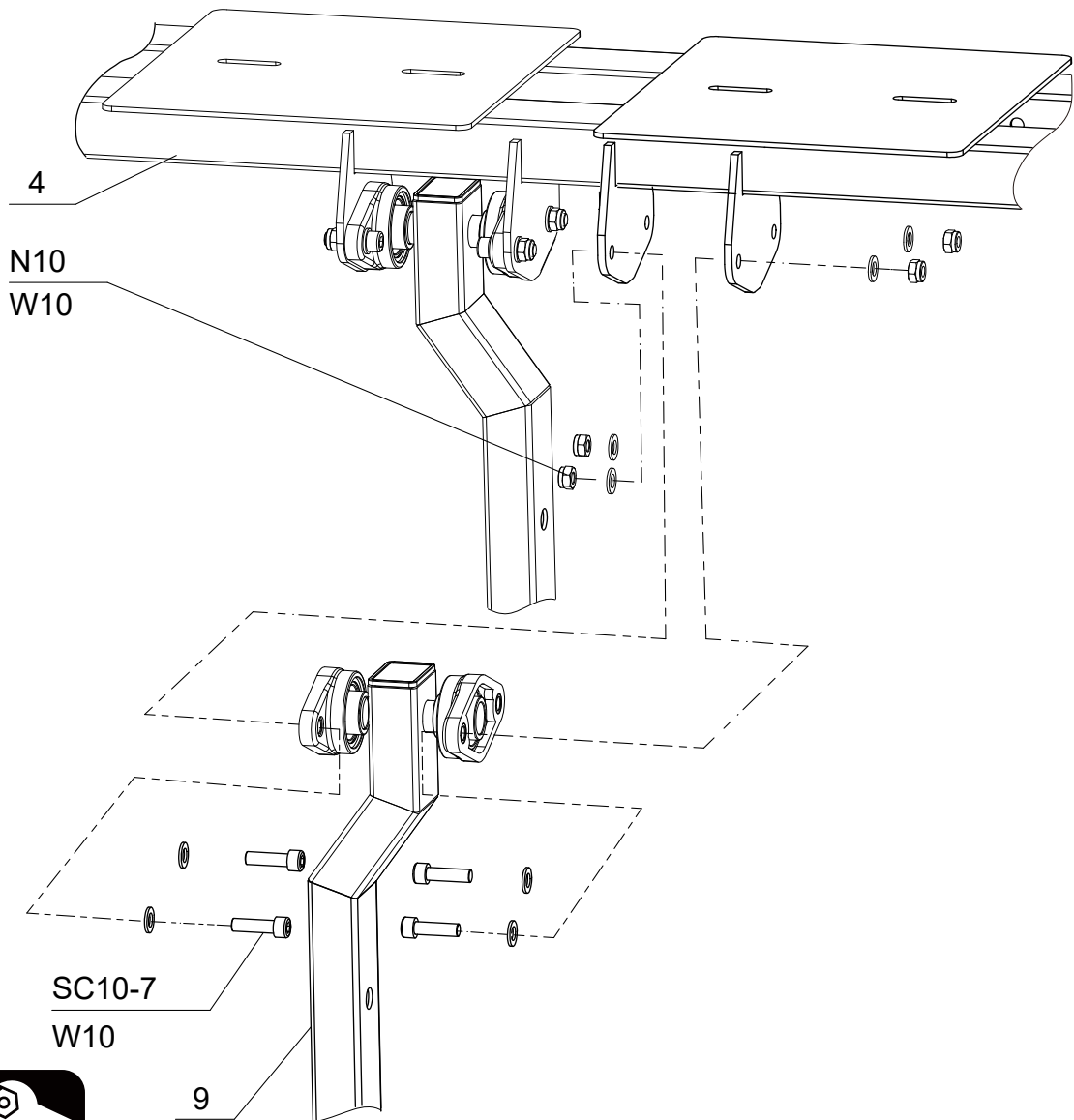



50%



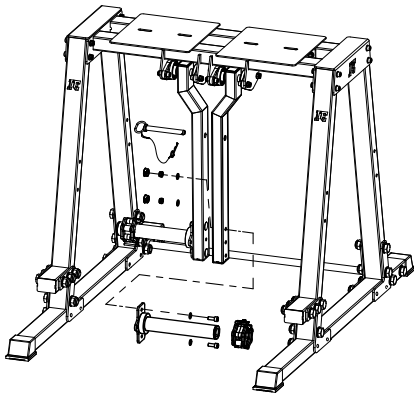



# STEP 7

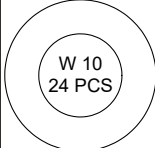

Tools	
	8 mm
	17 mm

Fixings	
	SC10-5 4 PCS
	

Parts	
Part No: 10 Name: Pin Q'TY:1	
Part No: 11 Name: Holding Tube Assy Q'TY:2	
Part No: 12 Name: Barbell Clip Q'TY:2	
Part No: 19 Name: Hole Cap Q'TY:4	

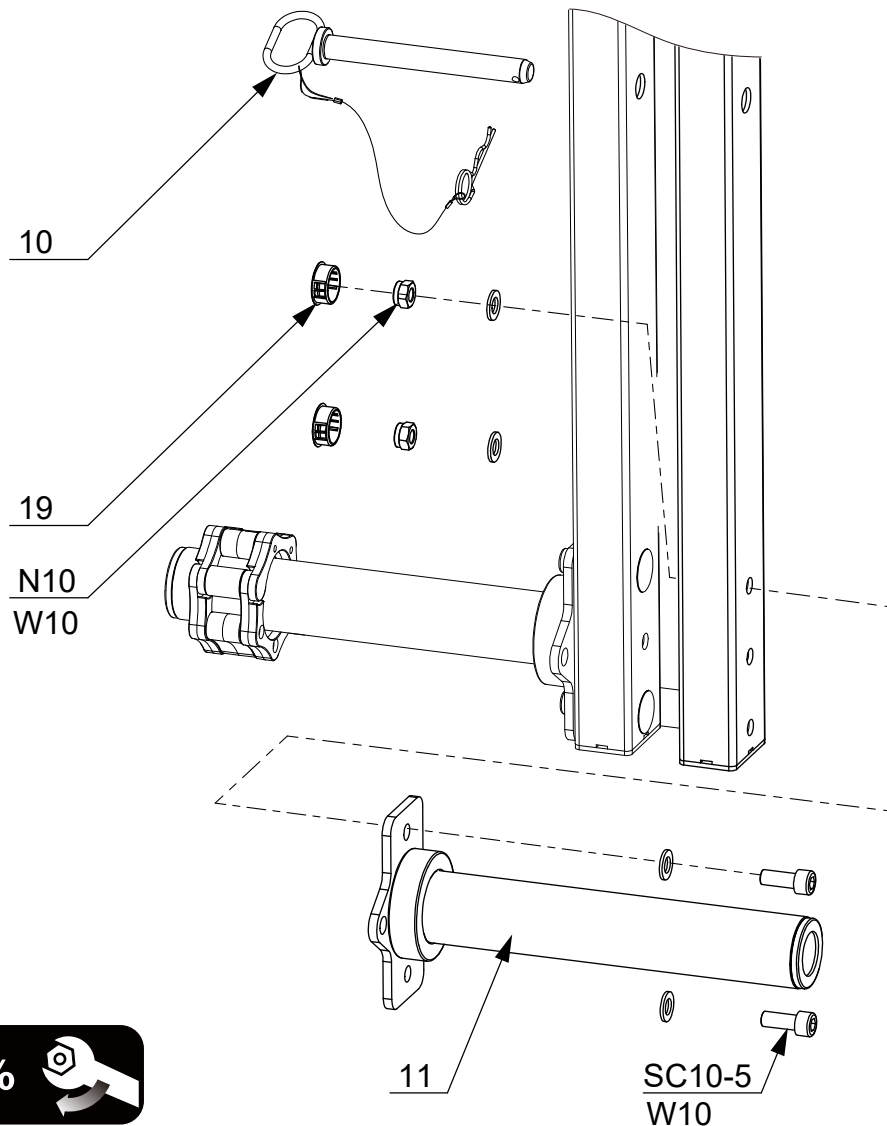

Assemble The Holding Tube Assy(#111), Pin(#10) And The Barbell Clip(#12).

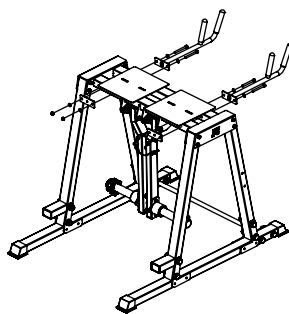

# STEP 8



## Tools

	16(17)mm
	8 mm

## Parts

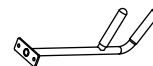

Part No: 13  
Name: Handle  
Q'TY: 2



Part No: 14  
Name: Back Plate  
Q'TY: 2

## Fixings

4 PCS

W 10  
8 PCS

SC10-19

N 10  
4 PCS

Install The Handles (#13)  
On Both Side.

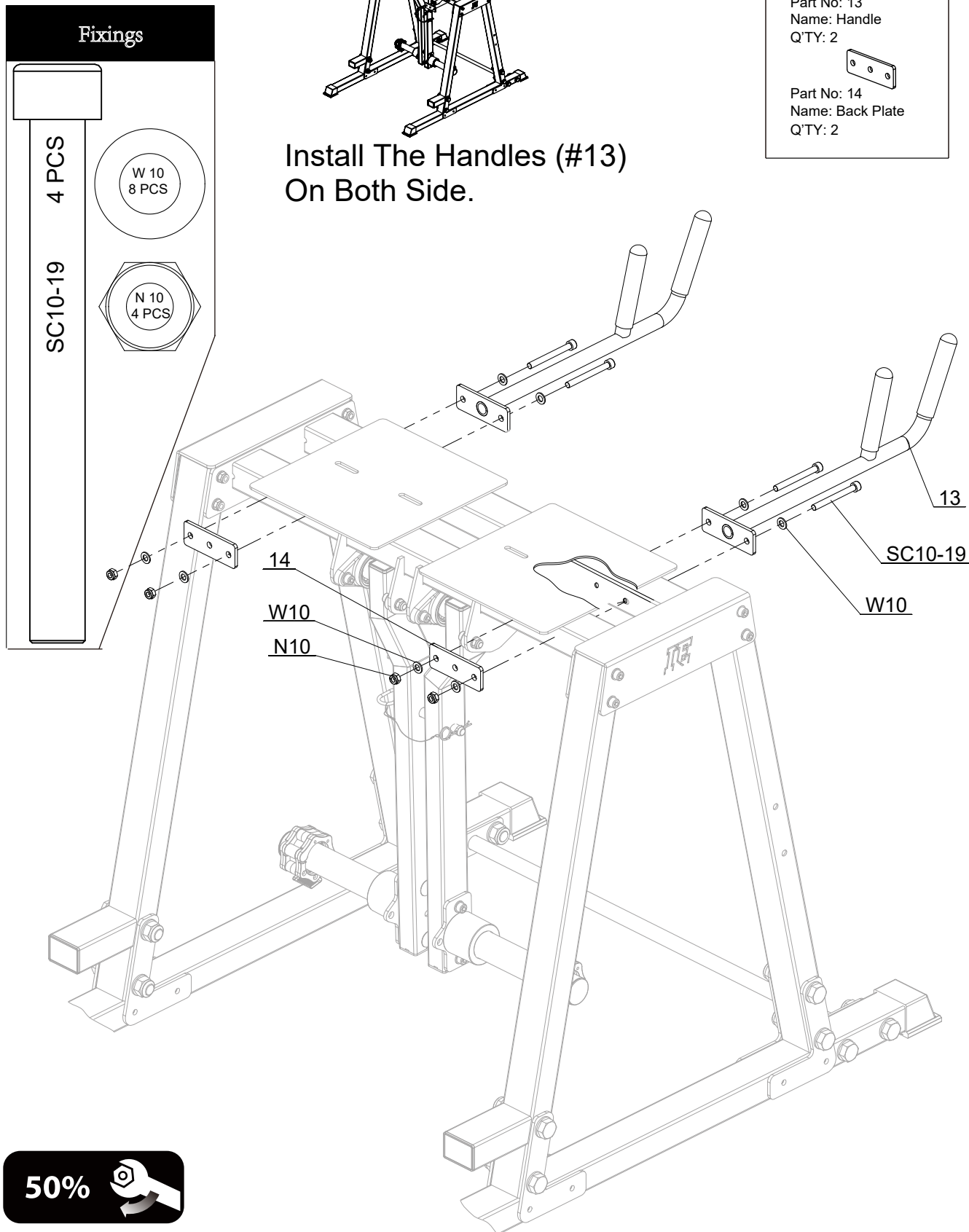

50%



# STEP 9

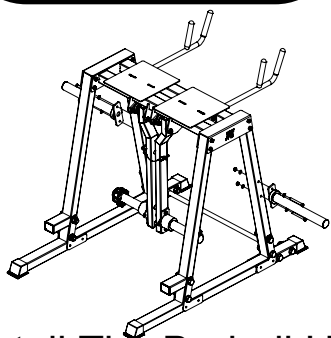

Install The Barbell Holding Tube Assy (#15) On Both Side.

## Tools



16(17)mm

8 mm

## Parts

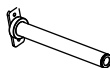

Part No: 15  
Name: Barbell Holding  
Tube Assy  
Q'TY: 2

## Fixings

W 10  
8 PCS

N 10  
4 PCS

4 PCS

SC10-19

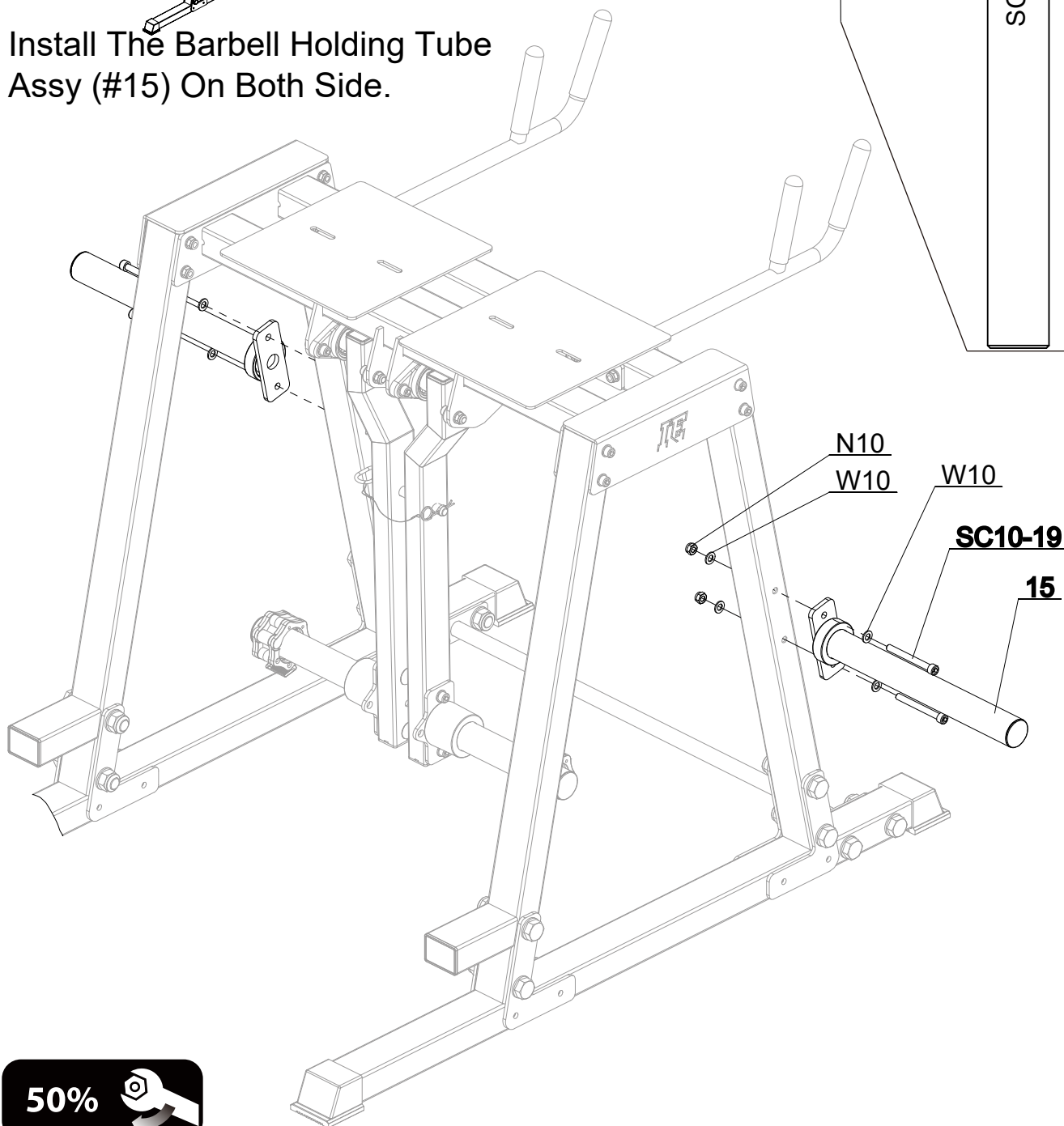

50%



# STEP 10

**Tools**



6 mm

**Parts**

Part No: 16  
Name: Pad  
Q'TY:2



Part No: 18  
Name: Ankle Strap Belt  
Q'TY:2



Part No: 17  
Name: Carabiner  
Q'TY:2



**Fixings**

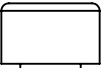

SC8-6 4PCS

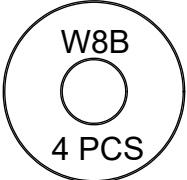

W8B  
4 PCS

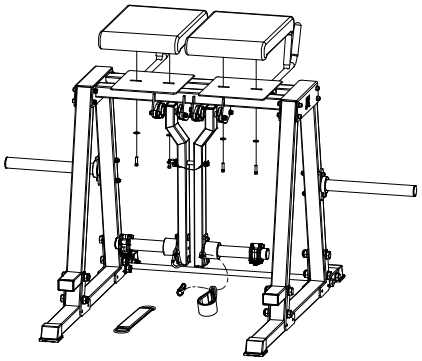

Assemble The Pads And The Ankle Strap Belts

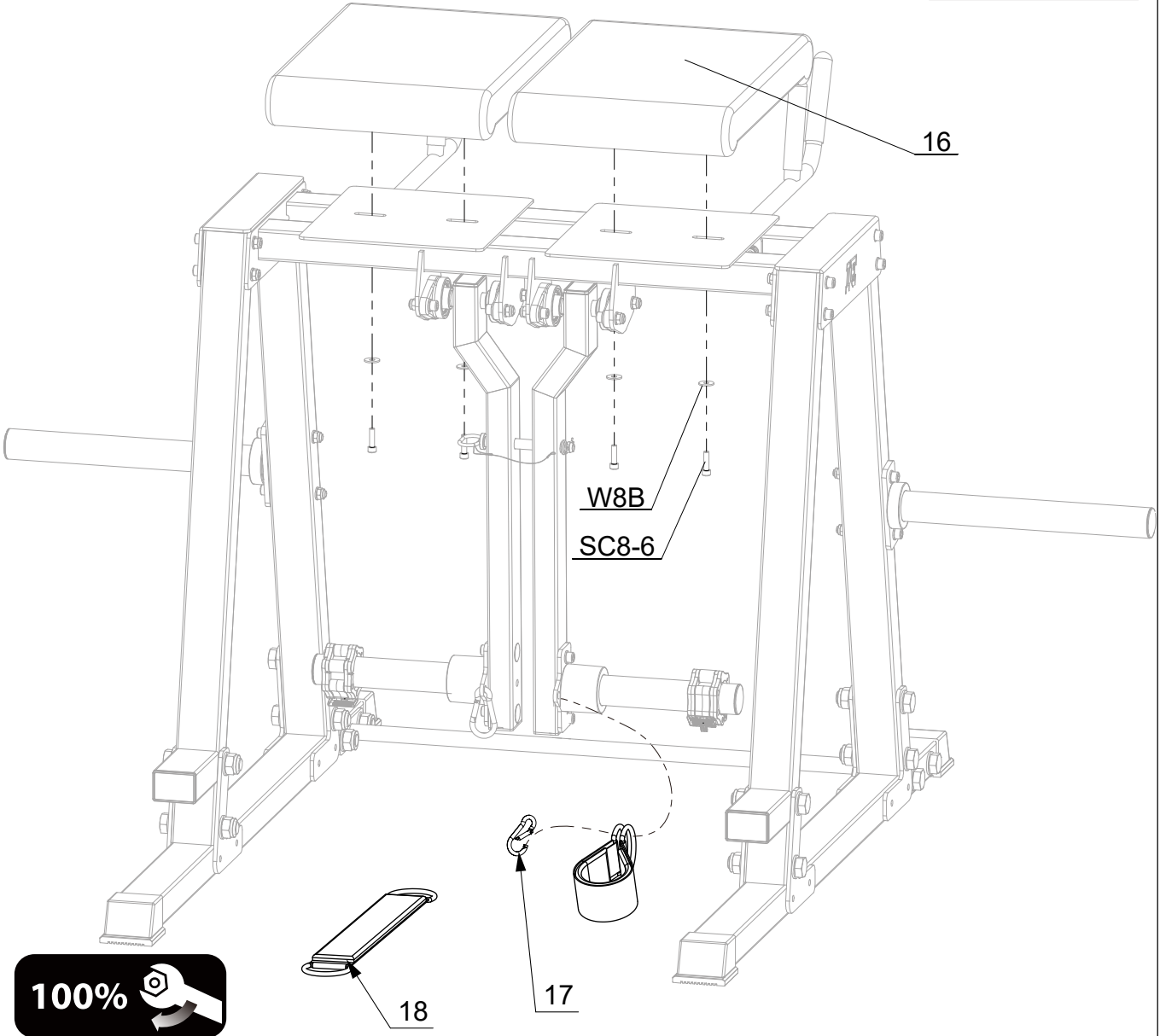

100% 

# PARTS LIST

PART #	DESCRIPTION	QTY
1	Bottom Tube Assy	2
2	Inclined Support Tube	2
3	Rear Inclined Support Tube	2
4	Top Frame	1
5	Backing Plate	2
6	Side Bended Plate	2
7	Bottom Lateral Tube Assy	1
8	Set Contained Bearing	4
9	Pendulum Arm	2
10	Pin	1
11	Holding Tube Assy	2
12	Barbell Clip	2
13	Handle	2
14	Back Plate	2
15	Barbell Holding Tube Assy	2
16	Pad	2
17	Carabiner	2
18	Ankle Strap Belt	2
19	Hole Cap	2
W8B	Big Washer $\Phi 8$	4
W10	Washer $\Phi 10$	56
W20	Washer $\Phi 20$	24
N10	Nut M10	28
N20	Nut M20	12
SC8-6	Socket Cap Screw M8X30	4
SC10-5	Socket Cap Screw M10X25	4
SC10-7	Socket Cap Screw M10X35	8
SC10-19	Socket Cap Screw M10X95	16
H10-20	Hex Head Bolt M20X100	4
H10-22	Hex Head Bolt M20X110	8