

**IRONEDGE.**

# Bench Pull

## Setup Instructions

 CAUTION: Read all precautions and instructions before using this equipment. Save this manual for future reference.

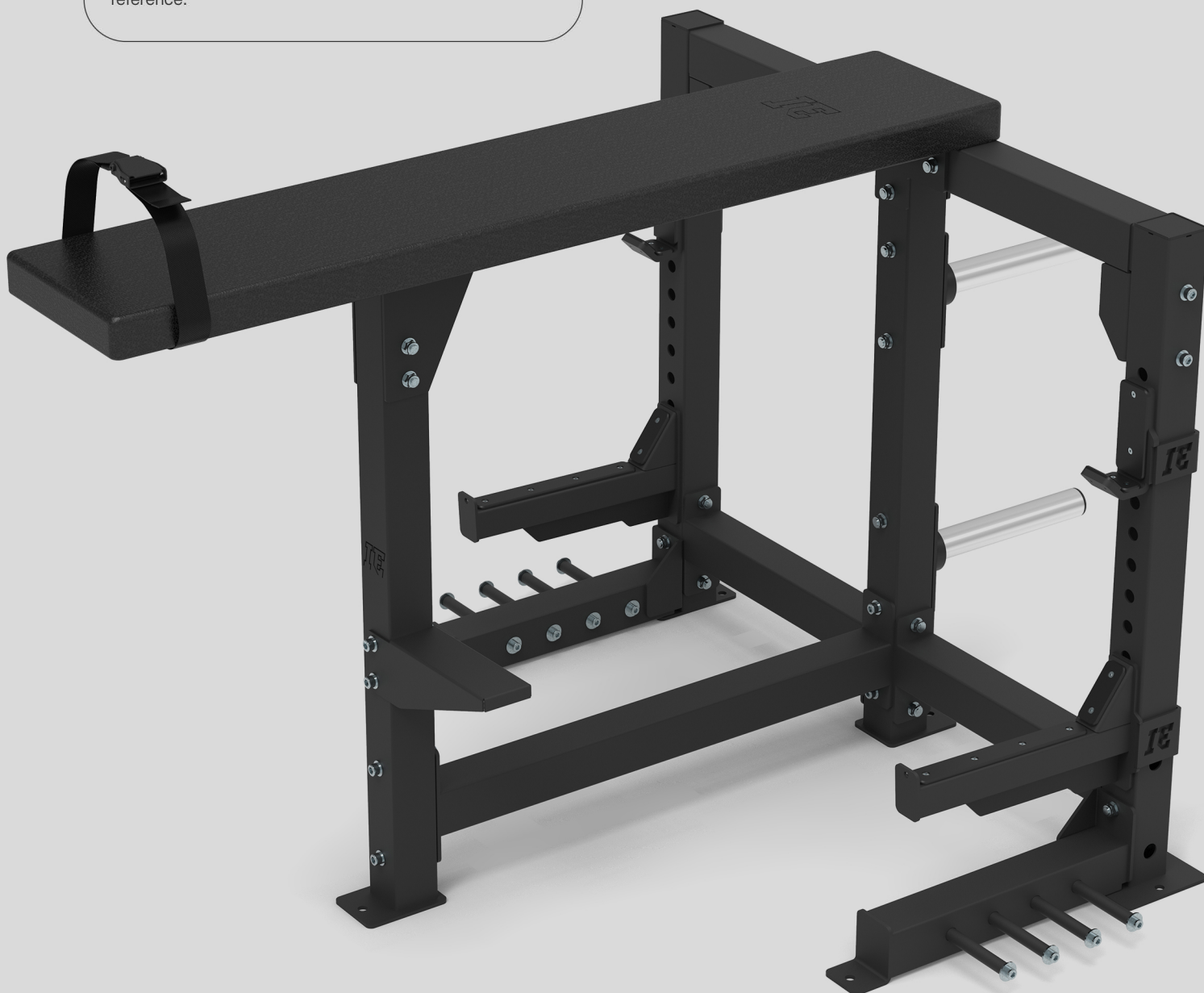

# Table Of Contents

Assembly Instructions.....	2-10
Part List.....	11

# STEP 1

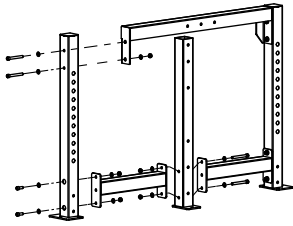

## Assemble The Main Frame 1/3

### Parts

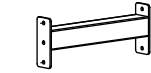

Part No: 1  
Name: Front Lower  
Connecting Tube Assy  
Q'TY: 2



Part No: 2  
Name: Front Middle  
Upright Tube Assy  
Q'TY: 1

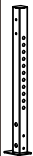

Part No: 3  
Name: Side Vertical  
Tube Assy  
Q'TY: 2

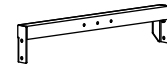

Part No: 4  
Name: Front Top Tube  
Assy  
Q'TY: 1

### Fixings

SC12-6 4PCS

SC12-20 4PCS

SC12-21 2PCS

W12  
18PCS

N12  
8PCS

### Tools

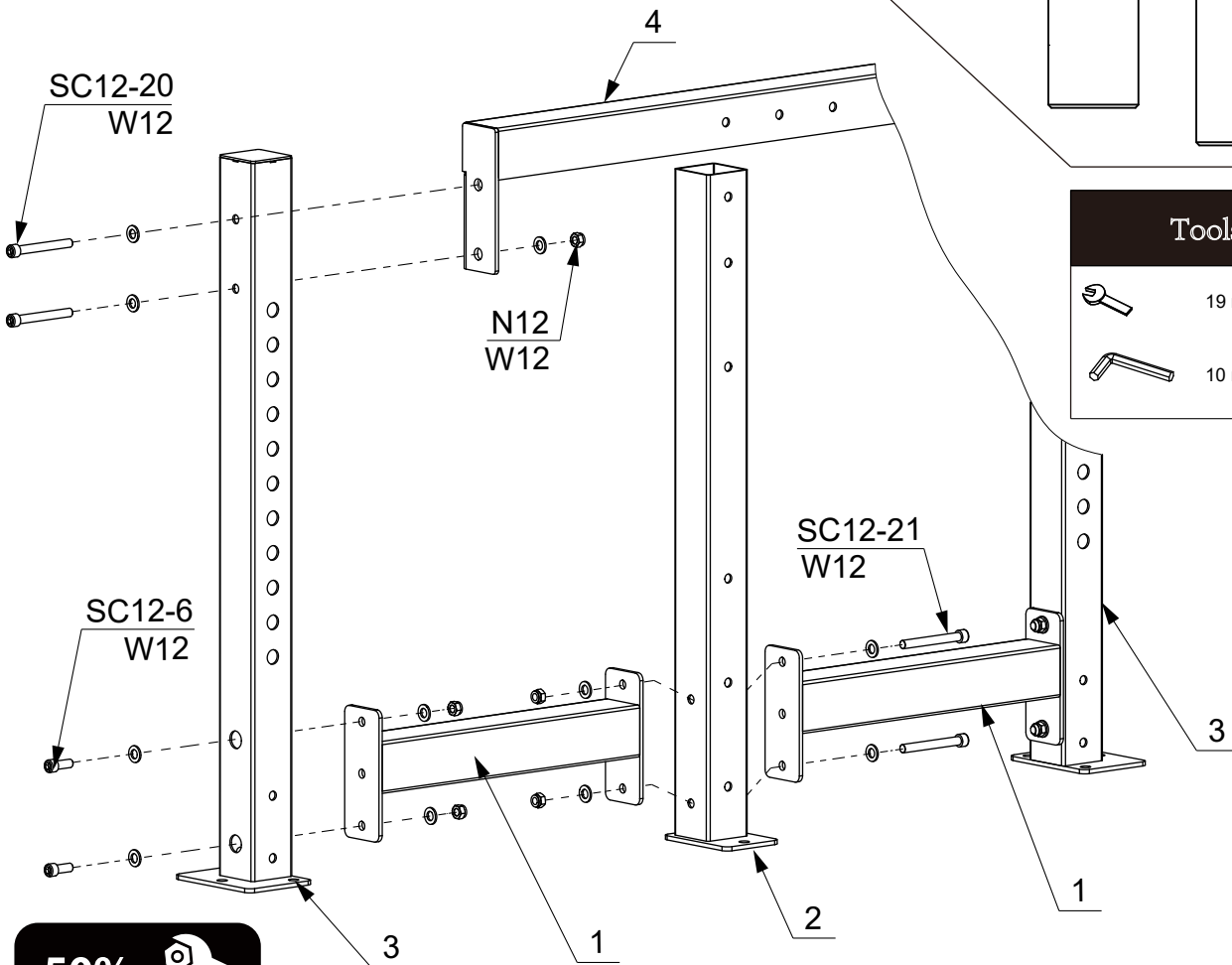
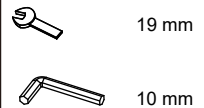



50%



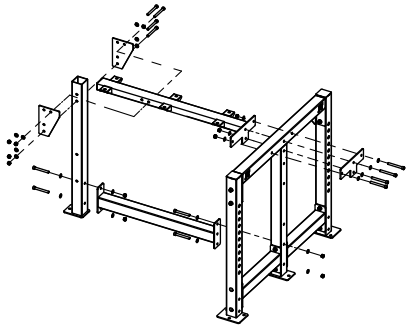

# STEP 2

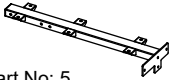



Assemble The Main frame 2/3  
(Assemble Part #5 With  
The Upright Tube #2.)

Parts	
	Part No: 5 Name: Pad Mounting Tube Assy Q'TY: 1
	Part No: 20 Name: Connecting T Plate Q'TY: 1

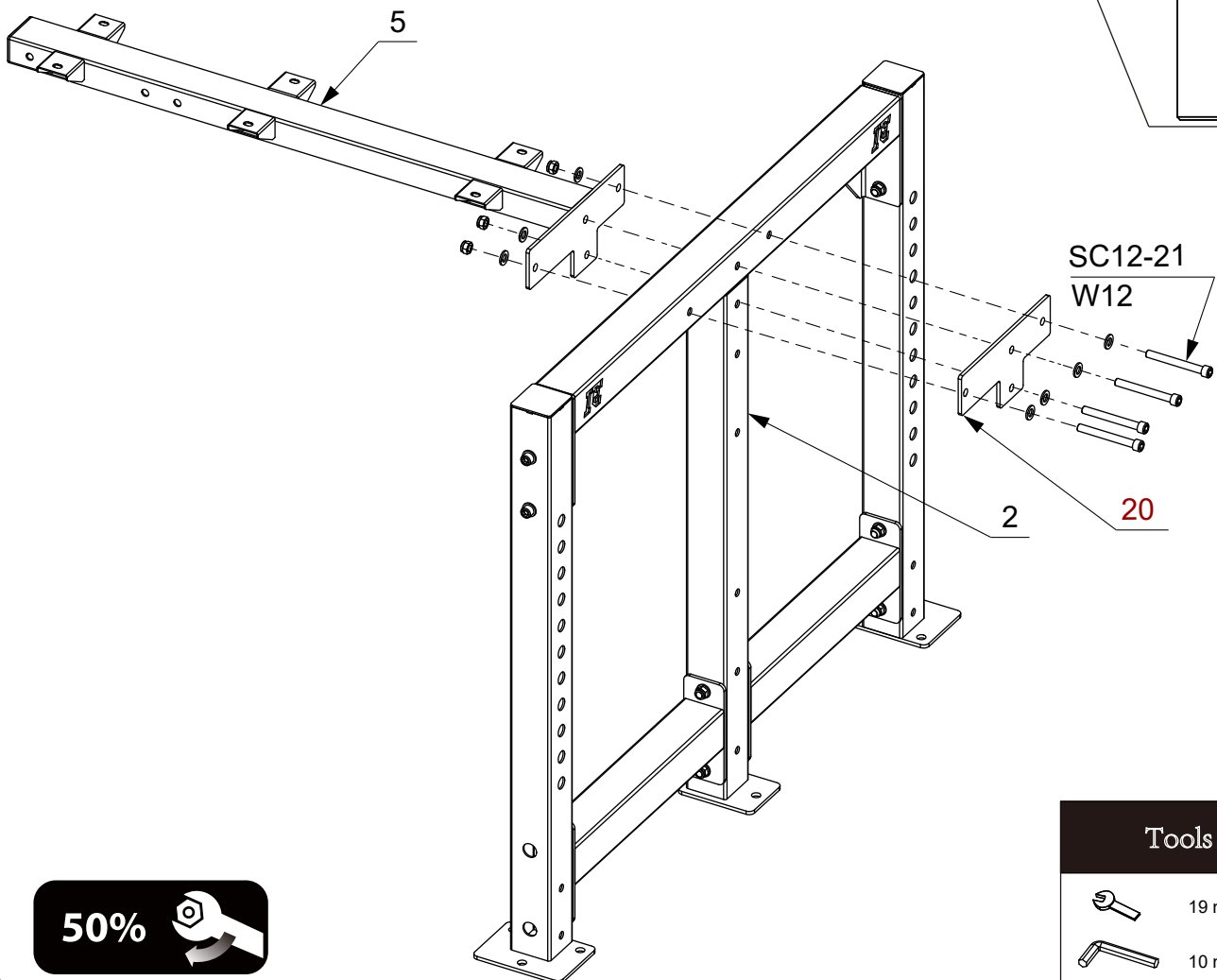
Fixings	
	SC12-21 4 PCS
	



50% 

Tools	
	19 mm
	10 mm

# STEP 3

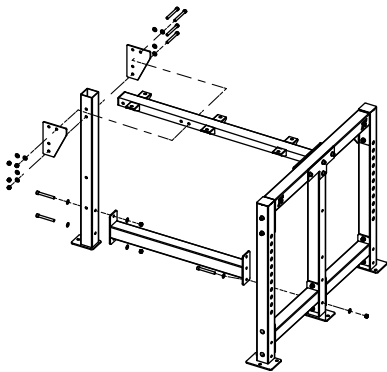

Parts	
Part No: 6	
Name: Connection Plate	
Q'TY: 2	
Part No: 7	
Name: Rear Upright Tube Assy	
Q'TY: 1	
Part No: 8	
Name: Bottom Lengthwise Tube Assy	
Q'TY: 1	

Fixings	
	W12 14 PCS
	N12 7 PCS
	SC12-20 3PCS
	SC12-21 4PCS

Assemble The Main frame 3/3  
(Assemble Part #8 With  
The Upright Tube #7 & #2.)

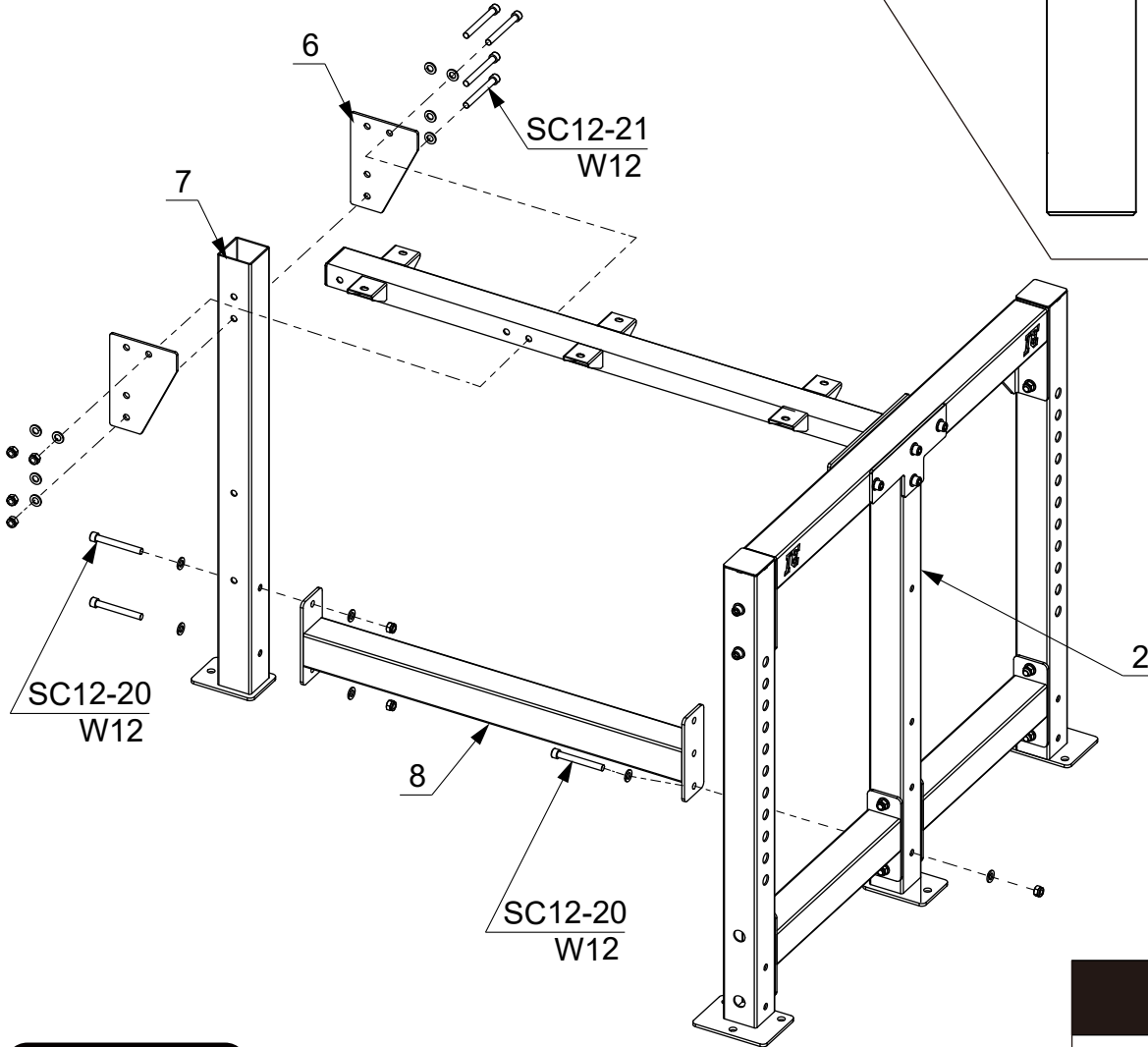

Tools	
	19 mm
	10 mm

# STEP 4

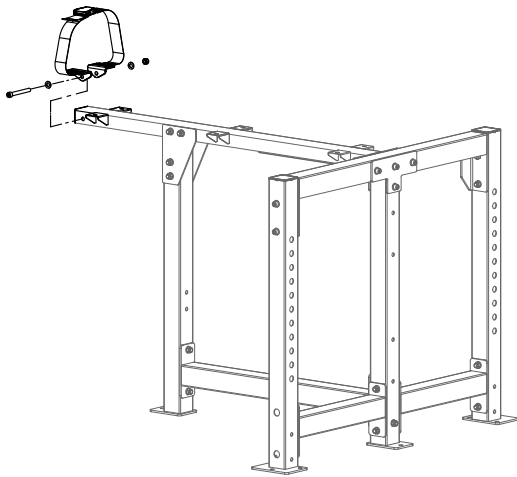

## Parts

Part No: 9  
Name: Anklet Belt  
Q'TY: 1



## Tools



10 mm

## Fixings

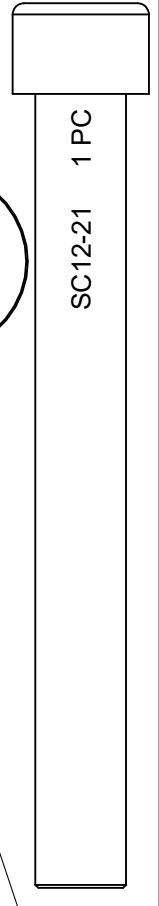
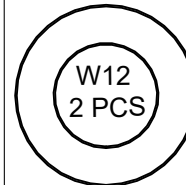

Assemble The Anklet Belt.

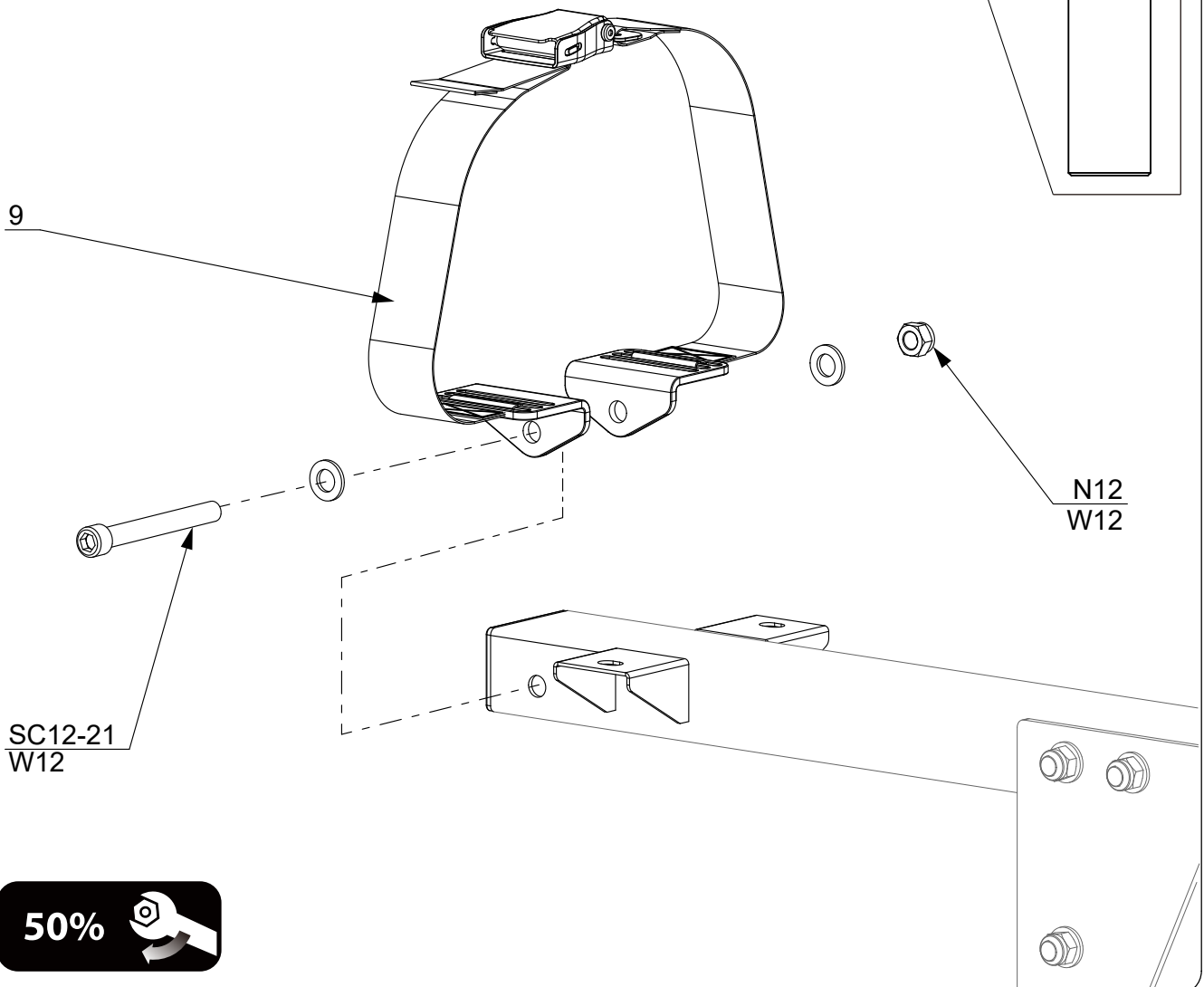

SC12-21  
W12

N12  
W12

50%



# STEP 5

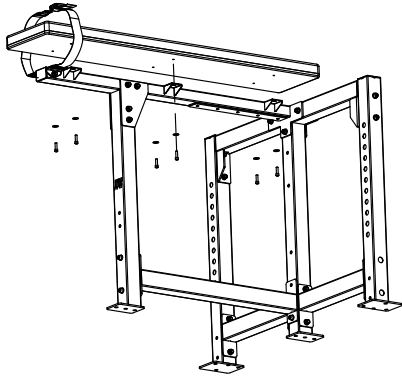

## Tools



6 mm

## Parts



Part No: 10  
Name: Pad  
Q'TY: 1

## Fixings

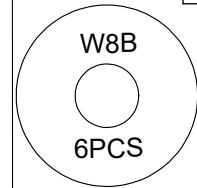

W8B  
6PCS

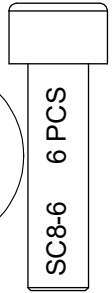

SC8-6 6 PCS

Assemble The Pad.

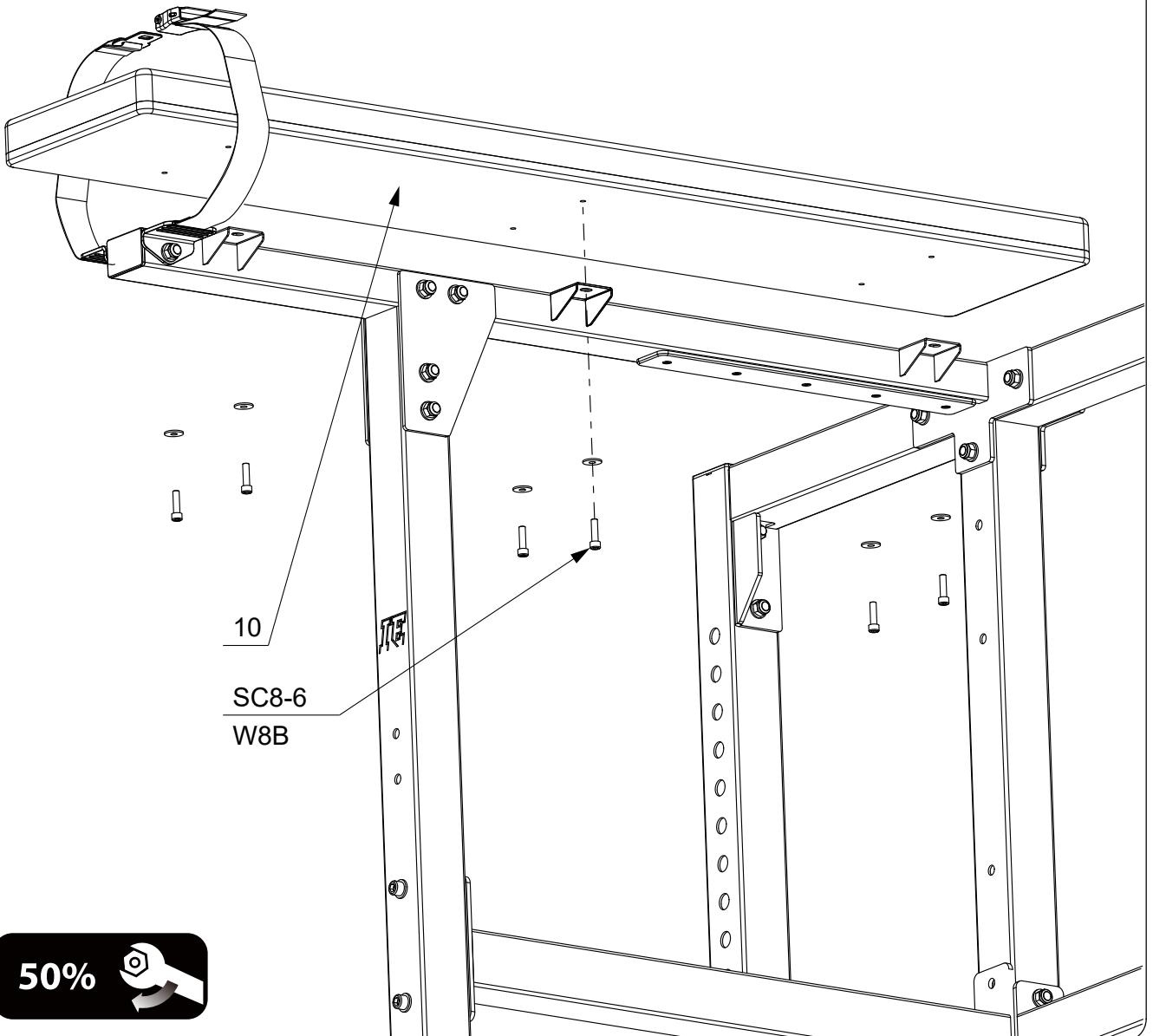

50%



# STEP 6

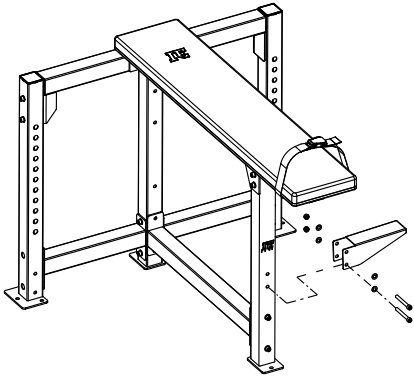

Assemble The Pedal .

## Parts

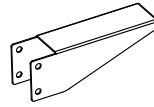

Part No: 11  
Name: Pedal  
Q'TY: 1

## Fixings



SC12-20 2PCS

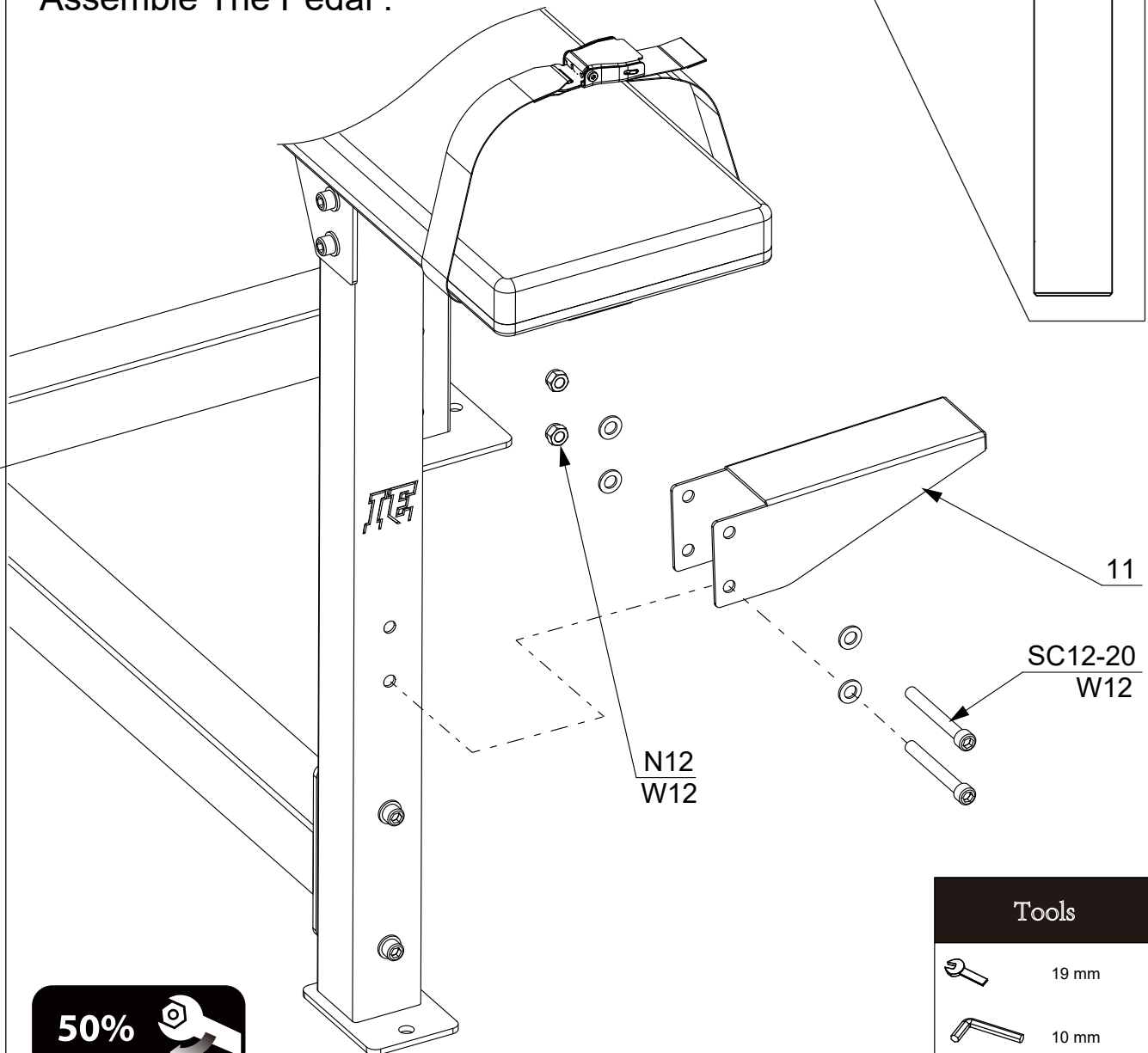

50%



## Tools



# STEP 7

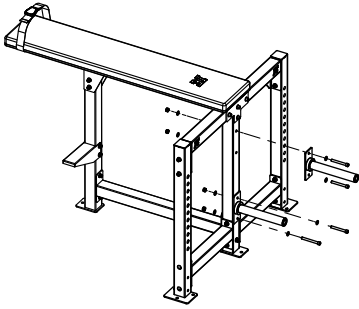

Assemble The Barbell Storage Bar

## Parts

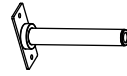

Part No: 12  
Name: Barbell Storage Bar  
Q'TY: 2

## Tools



19 mm



10 mm

## Fixings

SC12-20 3PCS

SC12-21 1PCS

W12  
8 PCS

N12  
4 PCS

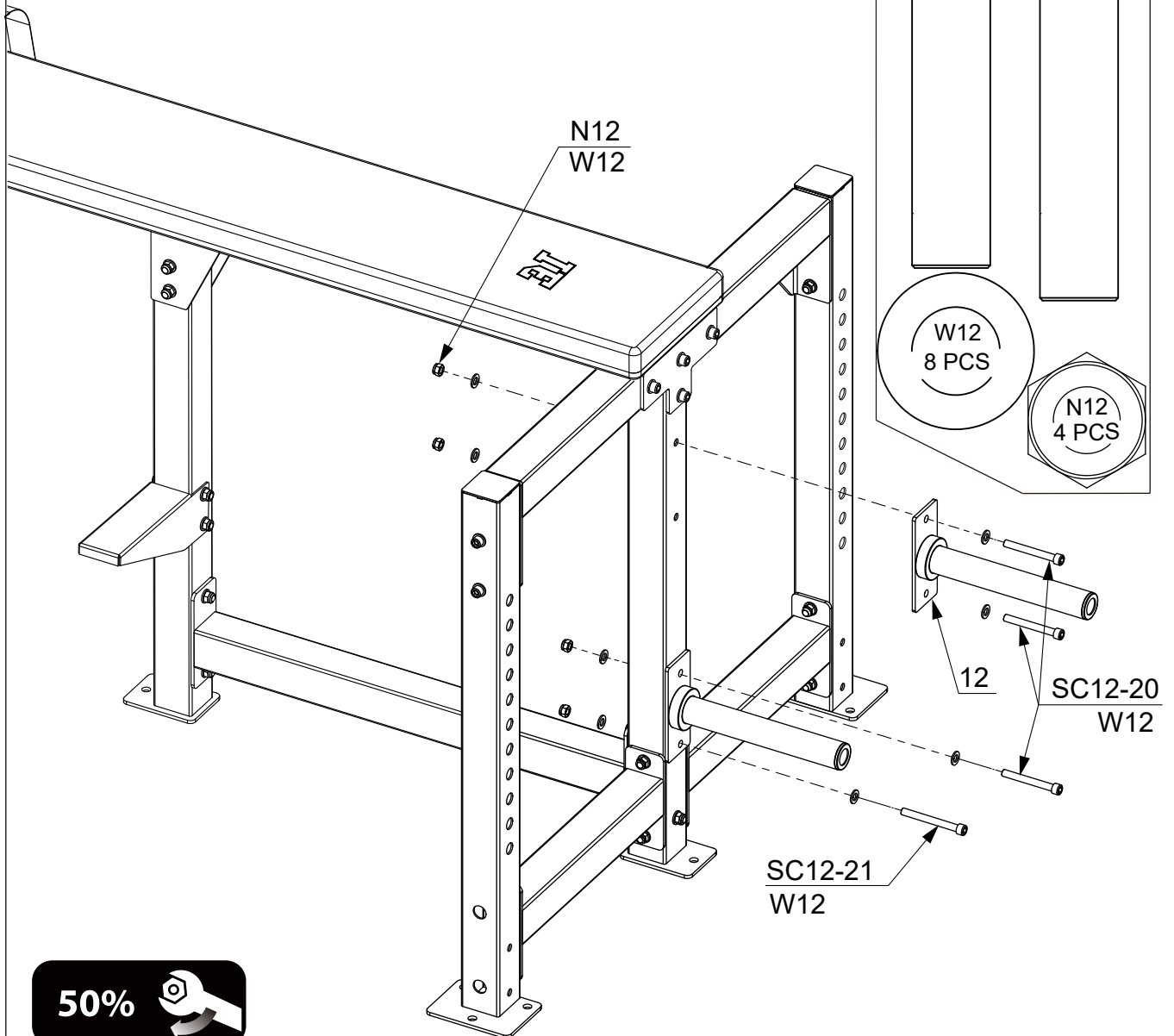

50%



# STEP 8

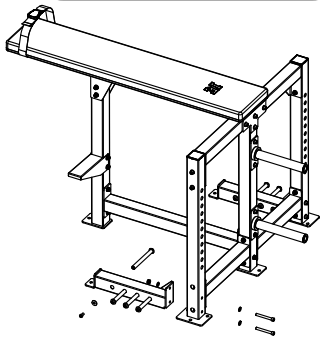

Assemble The Band Rod Mounting Frame (#15) And Band Rods (#14), And The Same Assembly On The Other Side.

## Parts

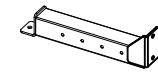

Part No: 13  
Name: Band Rod Mounting Frame Assy 1  
QTY:1



Part No: 14  
Name: Band Rod  
QTY:8

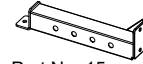

Part No: 15  
Name: Band Rod Mounting Frame Assy 2  
QTY:1

## Fixings

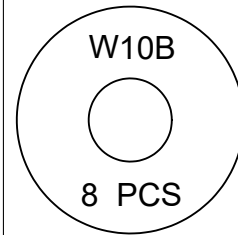
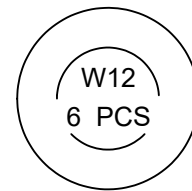
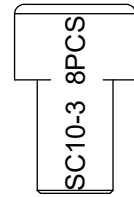

## Tools



19 mm



8,10 mm

SC10-4  
W10B

14

15

13

N12  
W12

SC12-20  
W12

100%



# STEP 9

Install The Hooks(#17 & #19) And The Safety Spotter Arms(#16 & #18)

## Parts

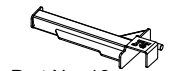

Part No: 16  
Name: Safety Spotter Arm 1  
Q'TY: 1



Part No: 17  
Name: Hook  
Q'TY: 1

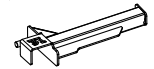

Part No: 18  
Name: Safety Spotter Arm 2  
Q'TY: 1



Part No: 19  
Name: Hook 2  
Q'TY: 1

